



# Ruijie RG-CS86 Series Switches

## Hardware Installation and Reference Guide

Document Version: V1.3

Date: 2023.12.12

Copyright © 2023 Ruijie Networks

## Copyright

Copyright © 2023 Ruijie Networks

All rights are reserved in this document and this statement.

Any reproduction, excerpt, backup, modification, transmission, translation or commercial use of this document or any portion of this document, in any form or by any means, without the prior written consent of Ruijie Networks is prohibited.

Trademark  and  are owned by Ruijie Networks.

All other trademarks or registered trademarks mentioned in this document are owned by their respective owners.

## Disclaimer

The products, services, or features you purchase are subject to commercial contracts and terms. Some or all of the products, services or features described in this document may not be within the scope of your purchase or use. Unless otherwise agreed in the contract, Ruijie Networks does not make any express or implied statement or guarantee for the content of this document.

Due to product version upgrades or other reasons, the content of this document will be updated from time to time. Ruijie Networks reserves the right to modify the content of the document without any notice or prompt.

This manual is for reference only. Ruijie Networks endeavors to ensure content accuracy and will not shoulder any responsibility for losses and damages caused due to content omissions, inaccuracies or errors.

# Preface

## Intended Audience

This document is intended for:

- Network engineers
- Technical support and servicing engineers
- Network administrators

## Technical Support

- Ruijie Networks website: <https://www.ruijienetworks.com/>
- Technical support website: <https://ruijienetworks.com/support>
- Case portal: <https://caseportal.ruijienetworks.com>
- Community: <https://community.ruijienetworks.com>
- Technical support email: [service\\_rj@ruijienetworks.com](mailto:service_rj@ruijienetworks.com)
- Skype: [service\\_rj@ruijienetworks.com](https://www.skype.com/people/service_rj@ruijienetworks.com)

## Conventions

### 1. Conversions

Convention	Description
<b>Bold font</b>	Commands, command options, and keywords are in <b>bold font</b> .
<i>Italic font</i>	Arguments for which you supply values are in <i>italic font</i> .
[ ]	Elements in square brackets are optional.
{ x   y   z }	Alternative keywords are grouped in braces and separated by vertical bars.
[ x   y   z ]	Optional alternative keywords are grouped in brackets and separated by vertical bars.
&<1-n>	The argument before the sign (&) can be input for consecutive 1- n times.
//	Double slashes at the beginning of a line of code indicate a comment line.

### 2. Signs

The signs used in this document are described as follows:

---

 **Warning**

An alert that calls attention to important rules and information that if not understood or followed can result in data loss or equipment damage.

---

---

 **Caution**

An alert that calls attention to essential information that if not understood or followed can result in function failure or performance degradation.

---

---

 **Note**

An alert that contains additional or supplementary information that if not understood or followed will not lead to serious consequences.

---

---

 **Specification**

An alert that contains a description of product or version support.

---

### 3. Note

The manual offers configuration information (including model, port type and command line interface) for indicative purpose only. In case of any discrepancy or inconsistency between the manual and the actual version, the actual version prevails.

# 1 Product Overview

RG-CS86 series multi-GE switches are the next-generation high-performance, high-security and multi-service layer 3 Ethernet switches developed by Ruijie Networks. As aggregation switches in a campus network, this series supports line-rate multi-layer switching, and is equipped with complete QoS policies for service-based traffic prioritization, guaranteeing the transmission of critical traffic at almost zero latency. RG-CS86 series multi-GE switches are 10GE switches. RG-CS86-24MG4VS-UP provides 24 multi-GE ports (100ME/1GE/2.5GE/5GE), with each port supporting IEEE 802.3bt Type 4 (90 W) PoE, and four 25GE ports. RG-CS86-48MG4VS2QXS-UPD provides 48 multi-GE ports (100ME/1GE/2.5GE/5GE), with the first 24 ports supporting IEEE 802.3bt Type 4 (90 W) PoE, and the last 24 ports supporting IEEE 802.3at Type 2 (30 W) PoE. It also provides four 25GE ports and two 40GE ports. RG-CS86-24XMG4XS4VS-UPD provides 24 multi-GE ports (100ME/1GE/2.5GE/5GE/10GE), with each port supporting IEEE 802.3bt Type 4 (90W) PoE. It also provides four 10GE ports and four 25GE ports. RG-CS86-12XMG4VS-UP provides 12 multi-GE ports (100ME/1GE/2.5GE/5GE/10GE), with each port supporting IEEE 802.3bt Type 4 (90 W) PoE. It also provides four 25G optical ports.

Specifications of RG-CS86 series switches:

Model	100GE QSFP28 Ethernet Ports	40GE QSFP+ Ethernet Ports	25GE SFP28 Ethernet Ports	10GE SFP+ Ethernet Ports	100ME/1GE/2.5GE/5GE Multi-GE Ethernet Ports	Redundant Fan Modules	Redundant Power Modules
RG-CS86-24MG4VS-UP	N/A	N/A	4	N/A	24	Fixed fan modules	Fixed power modules
RG-CS86-48MG4VS2QXS-UPD	N/A	2	4	N/A	48	2+1	1+1
RG-CS86-24XMG4XS4VS-UPD	N/A	N/A	4	4	24	2+1	1+1
RG-CS86-12XMG4VS-UP	N/A	N/A	4	N/A	12	Fixed fan modules	Fixed power modules

**Note**

- Four 25GE/10GE SFP28 ports of the RG-CS86 series multi-GE switches must operate at the same rate (25 Gbps or 10 Gbps). Operation at mixed rates is not supported.
- 25GE SFP28 ports of the RG-CS86 series multi-GE switches, when operating at the rate of 25 Gbps, support optical modules, but do not support Direct Attach Copper (DAC) cables. See Appendix B for supported optical module models and specifications.

- 10GE SFP+ ports of the RG-CS86 series multi-GE switches support 10GBASE-R and 1000BASE-X standards. When operating in 1000BASE-X mode, these ports support auto-negotiation without manually configuring the rate and duplex mode.
- 40GE QSFP+ ports of the RG-CS86 series multi-GE switches support both 40GE mode and 4x10GE mode.

## 1.1 RG-CS86-24MG4VS-UP

### Specifications

Model	RG-CS86-24MG4VS-UP
CPU	ARM processor, 1.25 GHz clock rate
BOOT ROM	16 MB
Flash Memory	1 GB
RAM	1GB DDR4, 32-bit bandwidth and 4-bit ECC
Expansion Module Slot	Not supported
Fan Module Slot	Fixed fan modules
Power Module Slot	Built-in Power Supply AC Input Rated voltage range: 100 V AC to 240 V AC Maximum voltage range: 90 V AC to 264 V AC Frequency: 50/60 Hz Rated current per circuit: 6 A
Max. Power Consumption	< 120 W
Supported Optical Module Types	For details, see Appendix B. The supported optical module types may update without prior notice. Please contact Ruijie Networks for details.
PoE	All RJ45 ports comply with the IEEE 802.3bt PoE standard. Each port can provide up to 90 W of power through PoE. The maximum power is subject to the actual power supply. The maximum number of PoE devices supported by the switch is determined by the PoE output power of the switch and the actual power of PoE devices.
POE Available Power	370 W
PoE Power Cable Pairs	Four pairs (1-2, 3-6, 4-5 and 7-8 pairs)

Temperature Alarm	Support temperature alarm and over-temperature protection.
EMC Certification	IEC62368-1
Safety Regulation Compliance	IEC62368-1
Altitude	0-5000 m (0-16404 ft.)
Operating Temperature	0°C to 45°C (32°F to 113 °F) at a height below 3000 m (9842 ft.) above the sea level Description Altitude 3000 m (9842 ft.) to 5000 m (16404 ft): The maximum temperature decreases by 1°C (1.8°F) each time the altitude increases by 220 m (721 ft).
Storage Temperature	-40°C to +70°C (-40°F to +158°F)
Operating Humidity	10% to 90% RH (non-condensing)
Storage Humidity	5% to 95% RH (non-condensing)
Weight	3.65 kg (8.82 lbs.)
Dimensions (W x D x H)	442 mm x 220 mm x 43.6 mm (17.40 in. x 29.92 in. x 6.89 in.)

**⚠ Caution**

- RG-CS86-24MG4VS-UP is a Class A product. In a domestic environment, this product may cause radio interference. In this case, users are advised to take proper measures against the interference.



- Electric shock hazard ! The fuse is in the neutral, and that the mains shall be disconnected to de-energize the phase conductors.

**! Warning**

This device is not suitable for use in places where children may be present.

**Appearance**

The front panel of the RG-CS86-24MG4VS-UP Ethernet switch is provided with 24 multi-GE electrical ports (100ME/1GE/2.5GE/5GE), with each port supporting IEEE 802.3bt Type 4 (90 W) PoE, four 25G optical ports, one management Ethernet electrical port (MGMT), one USB port, and one console port (Console). The following figures show the product appearance.

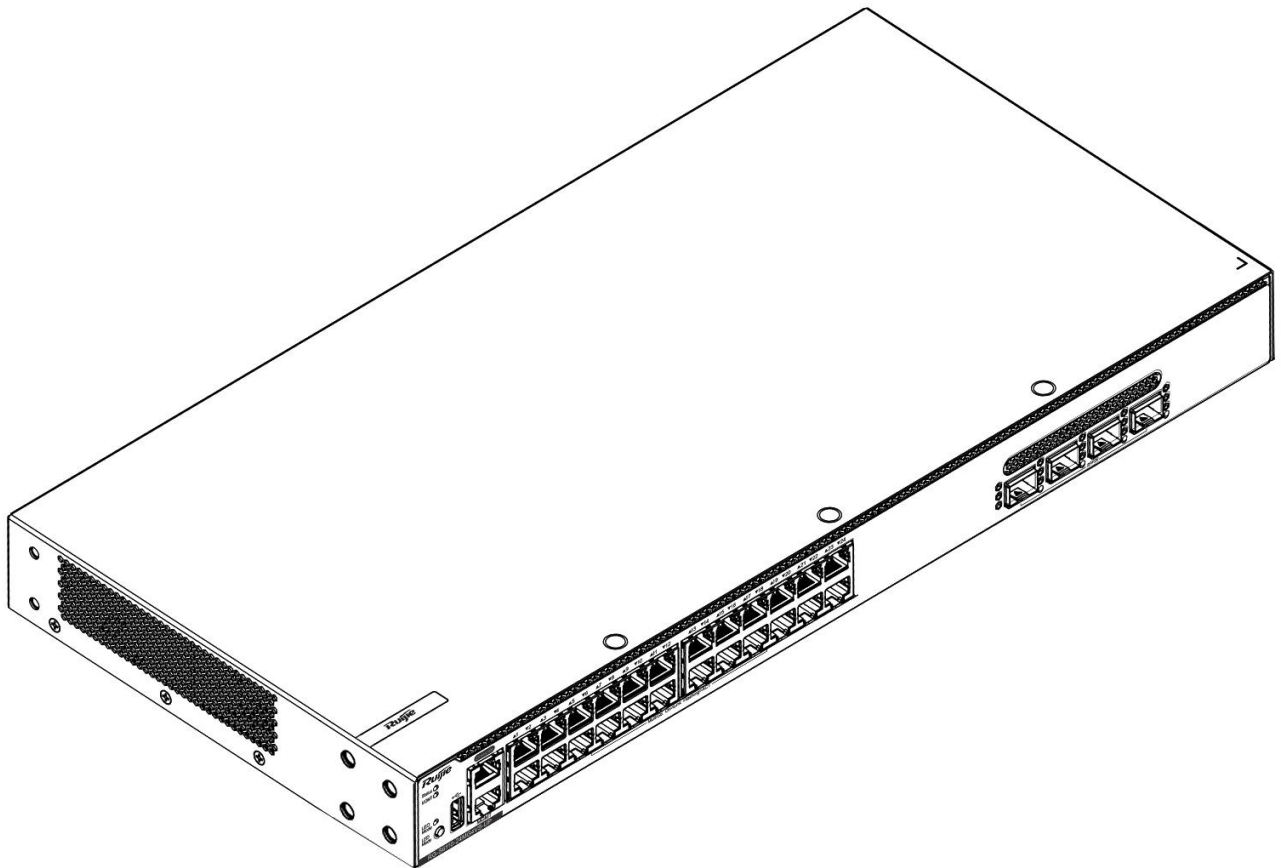
LED	Panel ID	Color	Status
-----	----------	-------	--------

System Status LED	SYS	Off	System is not powered on.
		Blinking green (3 Hz)	System is being initialized. Continuous blinking indicates a fault.
		Blinking green (10 Hz)	System is being located.
		Solid green	System is operating normally.
		Solid yellow	Temperature at the air intake and exhaust vents exceeds the threshold.
		Solid red	Temperature at air inlets and outlets exceeds the threshold. System is faulty.
Power Module Status LED	PWR1/PWR2	Off	The power module is not seated.
		Solid green	The power module is seated and providing power to the switch.
		Solid yellow	The model of the power module is not supported or cannot be read.
		Solid red	The redundant power module is not functioning properly or not connected to the AC power cord.
System Fan Module Status LED	FAN	Solid green	All fan modules are seated and functioning properly.
		Solid red	One fan module is faulty. Fan module model is not supported. One fan module is not seated.
PoE LED	PoE	Solid green	The LED indicates the switching status.
		Solid yellow	The LED indicates the PoE power supply status.
MGMT Port Status LED	MGMT	Off	No link is established on this port.
		Green	A 1000 Mbps link is established on this port.
		Blinking green	The port is sending and receiving traffic at 1000 Mbps.
		Yellow	A 100/10 Mbps link is established on this port.
		Blinking yellow	The port is sending and receiving traffic at 100/10 Mbps.
RJ45 port LED	1-24	Off	No link is established on this port.
		Solid green	A 1 Gbps/2.5 Gbps/5 Gbps link is established on this port.



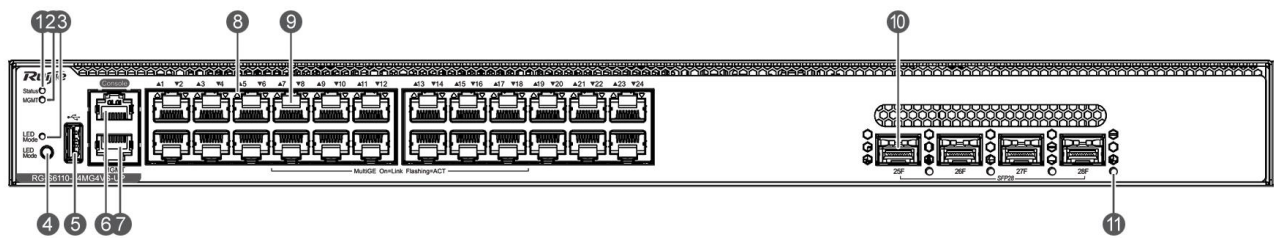
		Blinking green	The port is sending or receiving traffic at 1/2.5/5 Gbps.
		Solid yellow	A 100 Mbps link is established on this port.
		Blinking yellow	The port is sending and receiving traffic at 100 Mbps.
PoE Status LED	1-24	Off	PoE is disabled.
		Solid green	PoE is enabled.
		Solid yellow	The PoE port is overloaded or faulty.
SFP+ Port Status LED	25F-28F	Off	No link is established on this port.
		Solid green	A 10/1 Gbps link is established on this port.
		Blinking green	The port is sending and receiving traffic at 1/10 Gbps.
SFP28 Port Status LED	29F-32F	Off	No link is established on this port.
		Solid green	A 25/10 Gbps link is established on this port.
		Blinking green	The port is sending and receiving traffic at 25/10 Gbps.

Figure 1-1 Appearance of an RG-CS86-24MG4VS-UP Switch



Front Panel

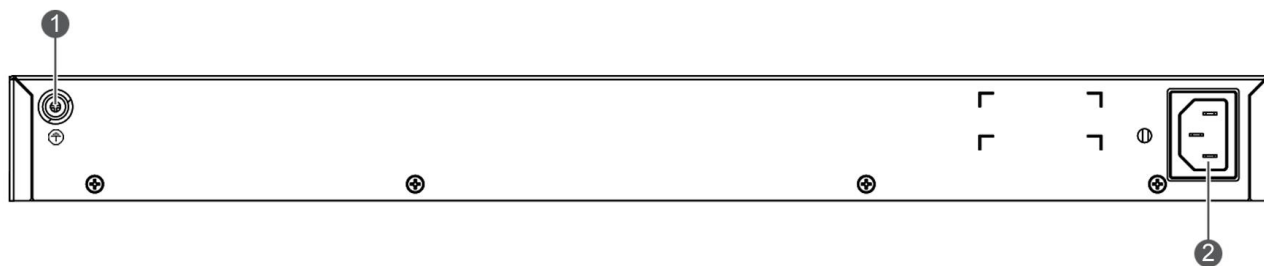
Figure 1-2 Front Panel of an RG-CS86-24MG4VS-UP Switch



Note	1. System status LED	7. Ethernet port for management
	2. MGMT interface status LED	8. Electrical port LED
	3. LED mode LED	9. 100ME/1GE/2.5GE/5GE multi-GE electrical ports
	4. LED mode button	10. SFP28 port
	5. USB port	11. SFP28 port LED
	6. Console port	

Rear Panel

**Figure 1-3 Rear Panel of an RG-CS86-24MG4VS-UP Switch**



Note      1. Grounding stud  
               2. AC power connector

**External Ports**

The RG-CS86-24MG4VS-UP switch provides the following ports:

- USB port: The USB port is the interface into which you plug your USB storage device for online upgrade or log storage.

**Note**

To ensure data security and prevent damage to your device, please use USB flash drives of well-known brands and good quality. The USB port is compatible with most USB controllers and may not recognize some models of USB flash drives.

**Note**

The RG-CS86-24MG4VS-UP switch supports configuration, maintenance, management, program loading and system debugging through console.

- Console port: The console port is an RS-232 port that uses an RJ45 connector. The console port is used to connect a PC directly to the management system for debugging, configuration, maintenance, management and program loading.
- Management port: The management port is an out-of-band Ethernet port that uses an RJ45 connector. You can manage and maintain the device remotely by connecting the management port to the Ethernet port of a PC with an Ethernet cable.
- Multi-GE electrical ports: 24 100ME/1GE/2.5GE/5GE multi-GE electrical ports. Each port supports IEEE 802.3bt Type 4 (90 W) PoE.
- SFP28 ports: four 25GE/10GE SFP28 ports, supporting 25GE optical module, and 10GE optical module or DAC cable, but not 25GE copper cable. Four 25GE/10GE SFP28 ports multi-GE switches must operate at the same rate (25Gbps or 10Gbps). Operation at mixed rates is not supported.

**Note**

To ensure the traffic forwarding performance, these four SFP28 ports are recommended to operate at 25 Gbps.

**LEDs**

**LED Mode Button**

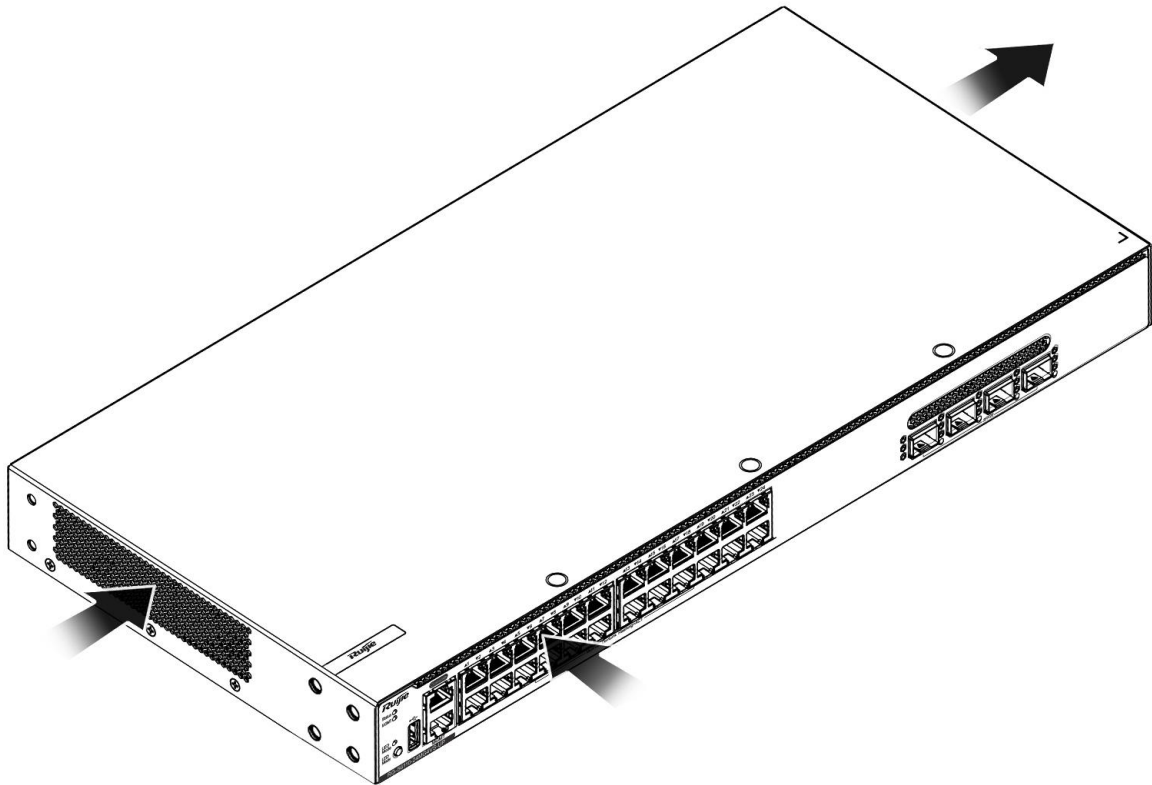
The LED Mode button is used to switch the LED mode. The green LED Mode indicator indicates the switching status. Press the LED Mode button, and the LED Mode indicator will turn yellow, indicating the PoE status. Press the LED Mode button again, the indicator switches to indicating the switching status.

If you want to switch the LED mode, press the button for over two seconds.

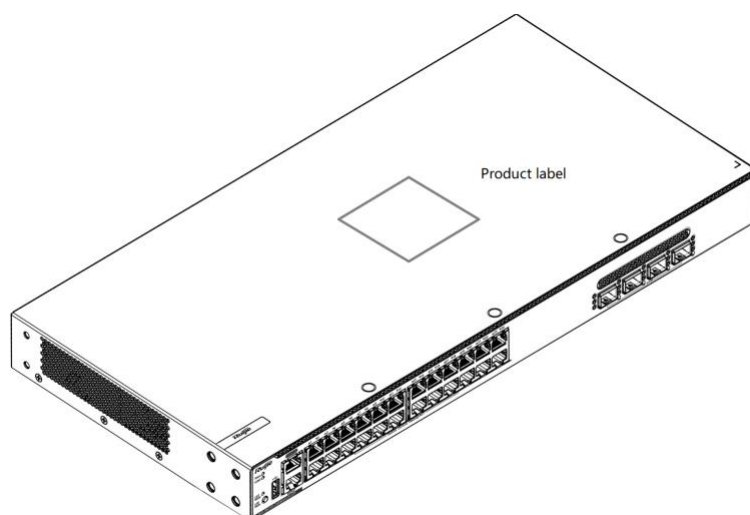
### Heat Dissipation

The RG-CS86-24MG4VS-UP switch adopts a left-to-right and front-to-right airflow design to ensure that the switch works properly in the specified environment. A minimum clearance of 100 mm (3.94 in.) must be maintained around the device to ensure proper ventilation. The following figure shows the airflow direction.

**Figure 1-4 Airflow Direction**



**Figure 1-5 RG-CS86-24MG4VS-UP Product information label**



## 1.2 RG-CS86-48MG4VS2QXS-UPD

### Specifications

Model	RG-CS86-48MG4VS2QXS-UPD
CPU	ARM processor, 1.25 GHz clock rate
BOOT ROM	16 MB
Flash Memory	1 GB
RAM	2GB DDR4, 32-bit bandwidth and 4-bit ECC
Expansion Module Slot	Not supported
Fan Module Slot	Quantity: 3 (2+1 redundancy. At least 2 fan modules are required.) Supported Fan module model: M2SFAN I-F
Power Module Slot	Quantity: 2 Supported power module model: RG-PA600I-P-F AC Input Rated voltage range: 100 V AC to 240 V AC Maximum voltage range: 90 V AC to 264 V AC Frequency: 50/60 Hz Rated Current Per Circuit: 8 A  Supported power module model: RG-PA1000I-P-F AC Input Rated Voltage Range:100V AC to 130V AC

	<p>Maximum Voltage Range: 90 AC to 143V AC</p> <p>Frequency: 50/60 Hz</p> <p>Rated Current Per Circuit: 12 A</p> <p>Rated Voltage Range: 200 V AC to 240 V AC</p> <p>Maximum Voltage Range: 180 AC to 264V AC</p> <p>Frequency: 50/60 Hz</p> <p>Rated Current Per Circuit: 8 A</p>
Max. Power Consumption	< 240 W (without POE)
Supported Optical Module Types	<p>For details, see Appendix B.</p> <p>The supported optical module types may update without prior notice. Please contact Ruijie Networks for details.</p>
PoE	<p>The first 24 ports support a maximum PoE power supply of 90 W, while the rest supports a maximum PoE power supply of 30 W. The maximum power is subject to the actual power supply.</p> <p>The maximum number of PoE devices supported by the switch is determined by the PoE output power of the switch and the actual power of PoE devices.</p>
POE Available Power	<p>Power supply: two RG-PA600I-P-F power modules</p> <p>AC Input: 90 V AC to 264 V AC</p> <p>PoE available power: 880 W</p> <p>Power supply: two RG-PA1000I-P-F power modules</p> <p>AC Input: 90 V AC to 143 V AC</p> <p>PoE available power: 1420 W</p> <p>AC Input: 180 V AC to 264 V AC</p> <p>PoE available power: 1600 W</p>
PoE Power Cable Pairs	Four pairs (1-2, 3-6, 4-5 and 7-8 pairs)
Temperature Alarm	Support temperature alarm and over-temperature protection.
EMC	IEC62368-1
Security Compliance	IEC62368-1
Altitude	0-5000 m (0-16404 ft.)

Operating Temperature	0°C to 45°C (32°F to 113 °F) at a height below 3000 m (9842 ft.) above the sea level  Description Altitude 3000 m (9842 ft.) to 5000 m (16404 ft): The maximum temperature decreases by 1°C (1.8°F) each time the altitude increases by 220 m (721 ft).
Storage Temperature	-40°C to +70°C (-40°F to +158°F)
Operating Humidity	10% to 90% RH (non-condensing)
Storage Humidity	5% to 95% RH (non-condensing)
Weight	6.11 kg (13.47 lbs), including three fan modules, and excluding power modules.
Dimensions (W × D × H)	442 mm × 220 mm × 43.6 mm (17.40 in. × 29.92 in. × 6.89 in.)

**⚠ Caution**

RG-CS86-48MG4VS2QXS-UPD is a Class A product. In a domestic environment, this product may cause radio interference. In this case, users are advised to take proper measures against the interference.

**i Note**

During operation, if one fan module fails, the remaining two fan modules can still support the normal operation of the device, provided that the faulty fan module is in place. If more than two fan modules fail, replace them immediately.

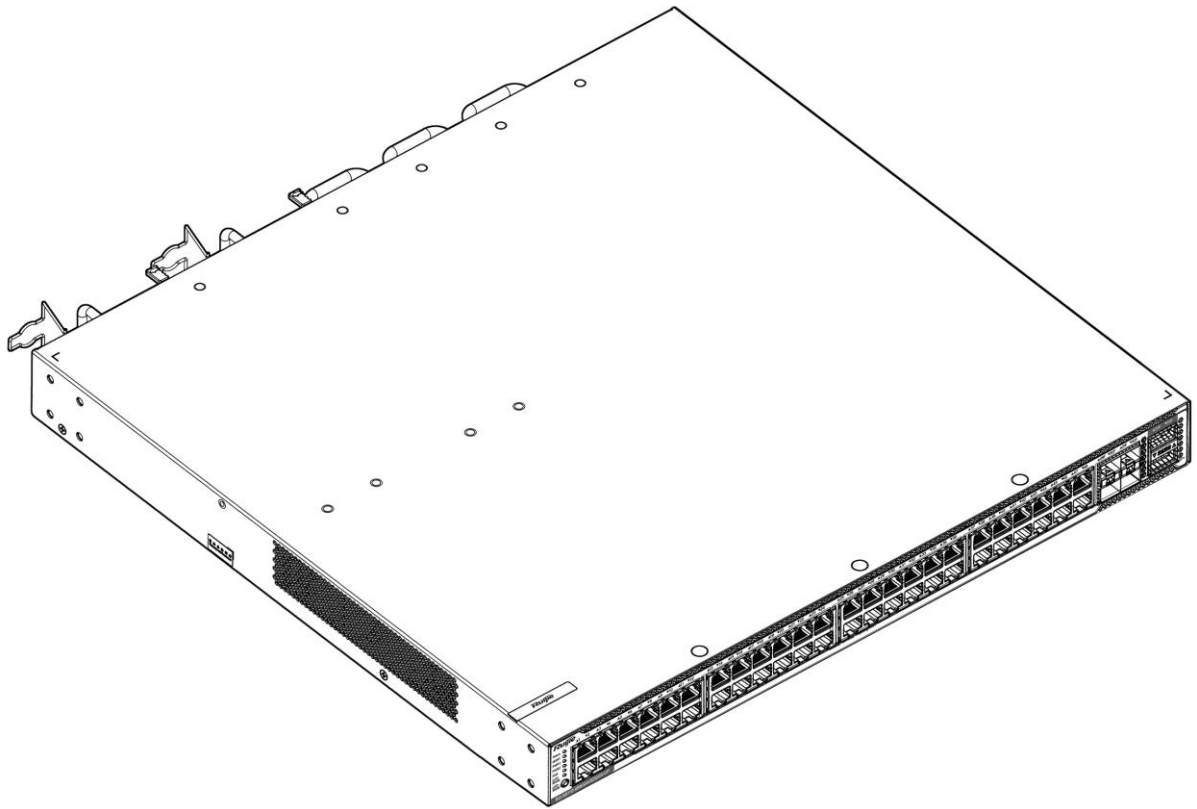
**! Warning**

This device is not suitable for use in places where children may be present.

**Appearance**

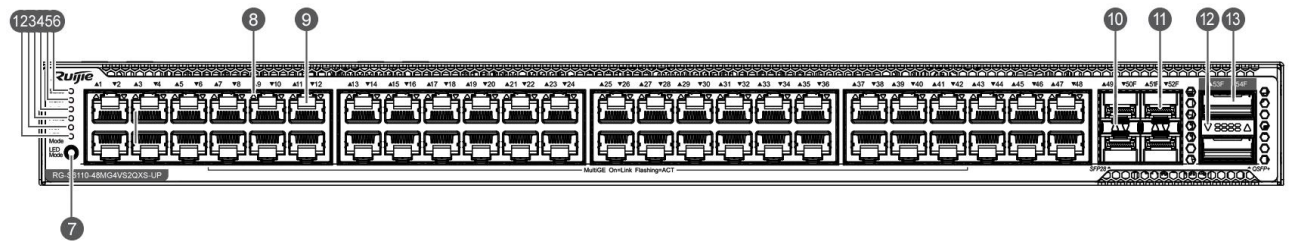
On the front panel of the RG-CS86-48MG4VS2QXS-UPD Ethernet switch, there are 48 multi-GE electrical ports (100ME/100ME/1GE/2.5GE/5GE), with the first 24 electrical ports supporting IEEE 802.3bt Type 4 (90 W) PoE, and the last 24 electrical ports supporting IEEE 802.3bt Type 4 (30 W) PoE, four 25GE optical ports, and two 40GE optical ports. On the rear panel, there are one management Ethernet electrical port (MGMT), one USB port, one console port (Console), two power module slots, and three fan module slots. The following figures show the product appearance.

Figure 1-6 Appearance of an RG-CS86-48MG4VS2QXS-UPD Switch



Front Panel

Figure 1-7 Front Panel of an RG-CS86-48MG4VS2QXS-UPD Switch

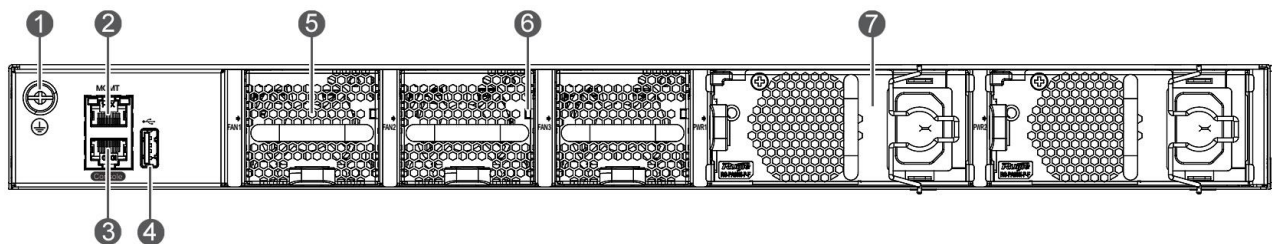


Note	1. LED mode LED	8. Electrical port LED
	2. Fan status LED (FAN)	9. 100ME/1GE/2.5GE/5GE multi-GE electrical ports
	3. PWR2 status LED	10. SFP28 port LED
	4. PWR1 status LED	11. SFP28 port
	5. Management port status LED	12. QSFP+ optical port LED
	6. System status LED	13. QSFP+ port
	7. LED mode button	

Rear Panel



**Figure 1-8 Rear Panel of an RG-CS86-48MG4VS2QXS-UPD Switch**



Note	1. Grounding stud	5. Fan module slot
	2. Ethernet port for management (MGMT)	6. Fan module status LED
	3. Console port	7. Power module slot
	4. USB port	

**External Ports**

The RG-CS86-48MG4VS2QXS-UPD switch provides the following ports:

- USB port: The USB port is the interface into which you plug your USB storage device for online upgrade or log storage.

**Note**

To ensure data security and prevent damage to your device, please use USB flash drives of well-known brands and good quality. The USB port is compatible with most USB controllers and may not recognize some models of USB flash drives.

**Note**

The RG-CS86-48MG4VS2QXS-UPD switch supports configuration, maintenance, management, program loading and system debugging through console.

- Console port: The console port is an RS-232 port that uses an RJ45 connector. The console port is used to connect a PC directly to the management system for debugging, configuration, maintenance, management and program loading.
- Management port: The management port is an out-of-band Ethernet port that uses an RJ45 connector. You can manage and maintain the device remotely by connecting the management port to the Ethernet port of a PC with an Ethernet cable.
- Multi-GE electrical ports: 48 100ME/1GE/2.5GE/5GE multi-GE electrical ports. The first 24 ports support IEEE 802.3bt Type 4 (90W) PoE, and the last 24 ports support IEEE 802.3bt Type 4 (30W) PoE.
- SFP28 ports: four 25GE/10GE SFP28 ports, supporting 25GE optical module, and 10GE optical module or DAC cable, but not 25GE copper cable. Four 25GE/10GE SFP28 ports multi-GE switches must operate at the same rate (25Gbps or 10Gbps). Operation at mixed rates is not supported.
- QSFP+ ports: two 40GE QSFP+ ports, supporting 40GE optical modules or DAC cables. 4 x 10GE mode is also supported.

**Note**

To ensure the traffic forwarding performance, these four SFP28 ports are recommended to operate at 25 Gbps.

**Note**

When ports 1-24 are used as downlink ports, ports 49F-50F and port 53F are recommended as uplink ports.  
 When ports 25-48 are used as downlink ports, ports 51F-52F and port 54F are recommended as uplink ports.

**LEDs**

LED	Panel ID	Color	Status
System Status LED	SYS	Off	System is not powered on.
		Blinking Green (3 Hz)	System is being initialized. Continuous blinking indicates a fault.
		Blinking Green (10 Hz)	System is being located, and can be remotely turned on or off by an O&M engineer.
		Solid green	System is operating normally.
		Solid yellow	Temperature at the air intake and exhaust vents exceeds the threshold.
		Solid red	Temperature at air inlets and outlets exceeds the threshold. System is faulty.
Power Module Status LED	PWR1/PWR 2	Off	The power module is not seated.
		Solid green	The power module is seated and providing power to the switch.
		Solid yellow	The model of the power module is not supported or cannot be read.
		Solid red	The redundant power module is not functioning properly or not connected to the AC power cord.
System Fan Module Status LED	FAN	Solid green	All fan modules are seated and functioning properly.
		Solid red	One fan module is faulty. Fan module model is not supported. One fan module is not seated.
PoE LED	PoE	Solid green	The LED indicates the switching status.
		Solid yellow	The LED indicates the PoE power supply status.
MGMT Port Status LED	MGMT	Off	No link is established on this port.
		Green	A 1000 Mbps link is established on this port.
		Blinking green	The port is sending and receiving traffic at 1000 Mbps.

		Yellow	A 100/10 Mbps link is established on this port.
		Blinking yellow	The port is sending and receiving traffic at 100/10 Mbps.
RJ45 port LED	1-48	Off	No link is established on this port.
		Solid green	A 1 Gbps/2.5 Gbps/5 Gbps link is established on this port.
		Blinking green	The port is sending or receiving traffic at 1/2.5/5 Gbps.
		Solid yellow	A 100 Mbps link is established on this port.
		Blinking yellow	The port is sending and receiving traffic at 100 Mbps.
PoE Status LED	1-48	Off	PoE is disabled.
		Solid green	PoE is enabled.
		Solid yellow	The PoE port is overloaded or faulty.
SFP28 Port Status LED	49F-52F	Off	No link is established on this port.
		Solid green	A 25/10 Gbps link is established on this port.
		Blinking green	The port is sending and receiving traffic at 25/10 Gbps.
QSFP+ Port Status LED	53F-54F	Off	No link is established on this port.
		Solid green	A 40G link is established on the port.
		Blinking green	The port is sending and receiving traffic at 40 Gbps.

#### LED Mode Button

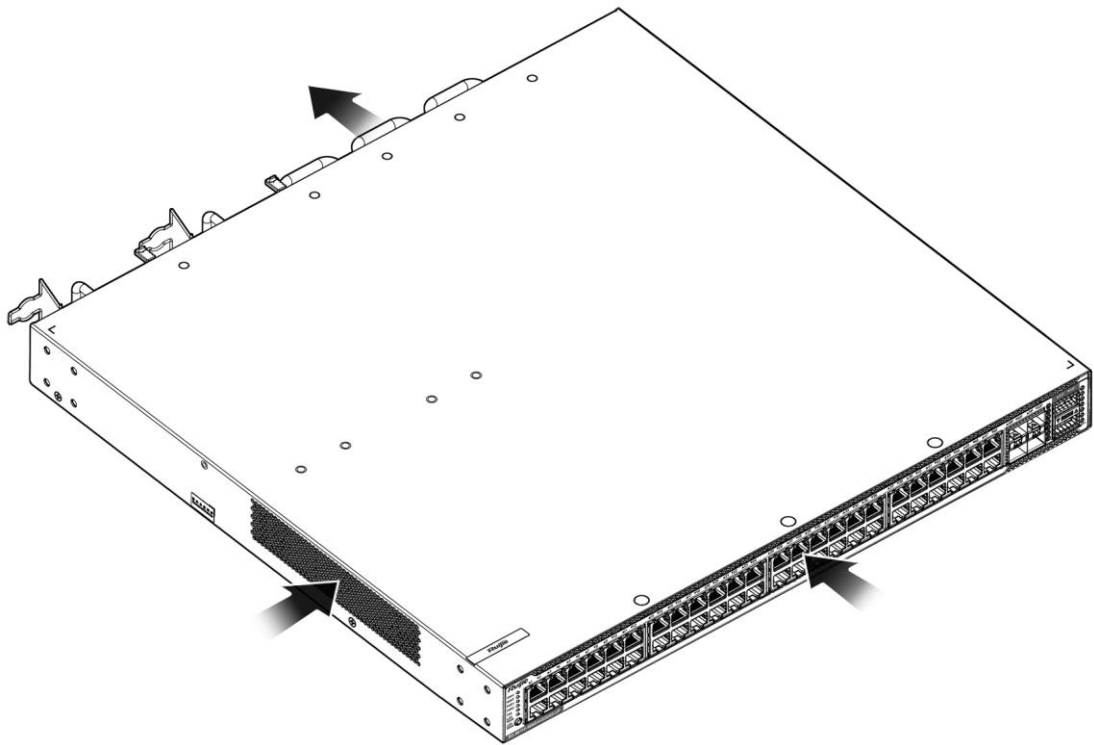
The LED Mode button is used to switch the LED mode. The green LED Mode indicator indicates the switching status. Press the LED Mode button, and the LED Mode indicator will turn yellow, indicating the PoE status. Press the LED Mode button again, the indicator switches to indicating the switching status.

If you want to switch the LED mode, press the button for over two seconds.

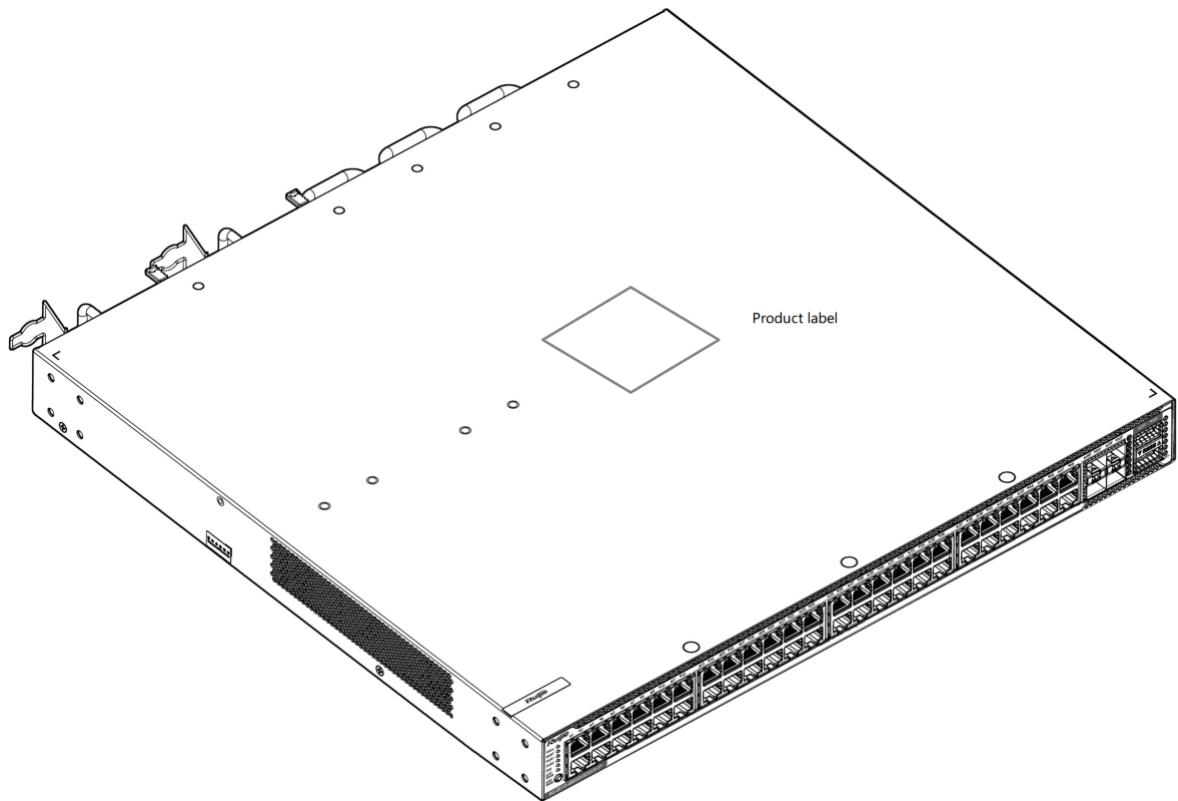
#### Heat Dissipation

RG-CS86-48MG4VS2QXS-UPD adopts the left-to-rear and front-to-rear airflow design to ensure normal operation in the specified environment. A minimum clearance of 100 mm (3.94 in.) must be maintained around the device to ensure proper ventilation. The following figure shows the airflow direction.

**Figure 1-9 Airflow Direction**



**Figure 1-10 RG-CS86-48MG4VS2QXS-UPD Product information label**



### 1.3 RG-CS86-24XMG4XS4VS-UPD

**Specifications**

Model	RG-CS86-24XMG4XS4VS-UPD
CPU	ARM processor, 1.25 GHz clock rate
BOOT ROM	16 MB
Flash Memory	1 GB
RAM	1GB, 32-bit bandwidth and 4-bit ECC
Expansion Module Slot	Not supported
Fan module slot	Quantity: 3 (2+1 redundancy. At least 2 fan modules are required.) Supported Fan module model: M2SFAN I-F
Power module slot	Quantity: 2 Supported power module model: RG-PA600I-P-F AC Input Rated voltage range: 100 V AC to 240 V AC Maximum voltage range: 90 V AC to 264 V AC Frequency: 50/60 Hz Rated Current Per Circuit: 8 A  Supported power module model: RG-PA1000I-P-F AC Input Rated Voltage Range:100V AC to 130V AC Maximum Voltage Range: 90 AC to 143V AC Frequency: 50/60 Hz Rated Current Per Circuit: 12 A  Rated Voltage Range: 200 V AC to 240 V AC Maximum Voltage Range: 180 AC to 264V AC Frequency: 50/60 Hz Rated Current Per Circuit: 8 A
Max. Power Consumption	< 120 W

Supported Optical Module Types	<p>For details, see Appendix B.</p> <p>The supported optical module types may update without prior notice. Please contact Ruijie Networks for details.</p>
PoE	<p>All RJ45 ports comply with the IEEE 802.3bt PoE standard. Each port can provide up to 90 W of power through PoE. The maximum power is subject to the actual power supply.</p> <p>The maximum number of PoE devices supported by the switch is determined by the PoE output power of the switch and the actual power of PoE devices.</p>
PoE Available Power	<p>Power supply: two RG-PA600I-P-F power modules</p> <p>AC Input: 90 V AC to 264 V AC</p> <p>PoE available power: 930 W</p> <p>Power supply: two RG-PA1000I-P-F power modules</p> <p>AC Input: 90 V AC to 143 V AC</p> <p>PoE available power: 1470 W</p> <p>AC Input: 180 V AC to 264 V AC</p> <p>PoE available power: 1650 W</p>
PoE Power Cable Pairs	Four pairs (1-2, 3-6, 4-5 and 7-8 pairs)
Temperature Alarm	Support temperature alarm and over-temperature protection.
EMC	IEC62368-1
Security Compliance	IEC62368-1
Altitude	0-5000 m (0-16404 ft.)
Operating Temperature	<p>0°C to 45°C (32°F to 113 °F) at a height below 3000 m (9842 ft.) above the sea level</p> <p>Description</p> <p>Altitude 3000 m (9842 ft.) to 5000 m (16404 ft): The maximum temperature decreases by 1°C (1.8°F) each time the altitude increases by 220 m (721 ft).</p>
Storage Temperature	-40°C to +70°C (-40°F to +158°F)
Operating Humidity	10% to 90% RH (non-condensing)
Storage	5% to 95% RH (non-condensing)

Humidity	
Weight	6.11 kg (13.47 lbs), including three fan modules, and excluding power modules.
Dimensions (W × D × H)	442 mm × 220 mm × 43.6 mm (17.40 in. × 29.92 in. × 6.89 in.)

**⚠ Caution**

RG-CS86-24XMG4XS4VS-UPD is a Class A product. In a domestic environment, this product may cause radio interference. In this case, users are advised to take proper measures against the interference.

**ℹ Note**

During operation, if one fan module fails, the remaining two fan modules can still support the normal operation of the device, provided that the faulty fan module is in place. If more than two fan modules fail, replace them immediately.

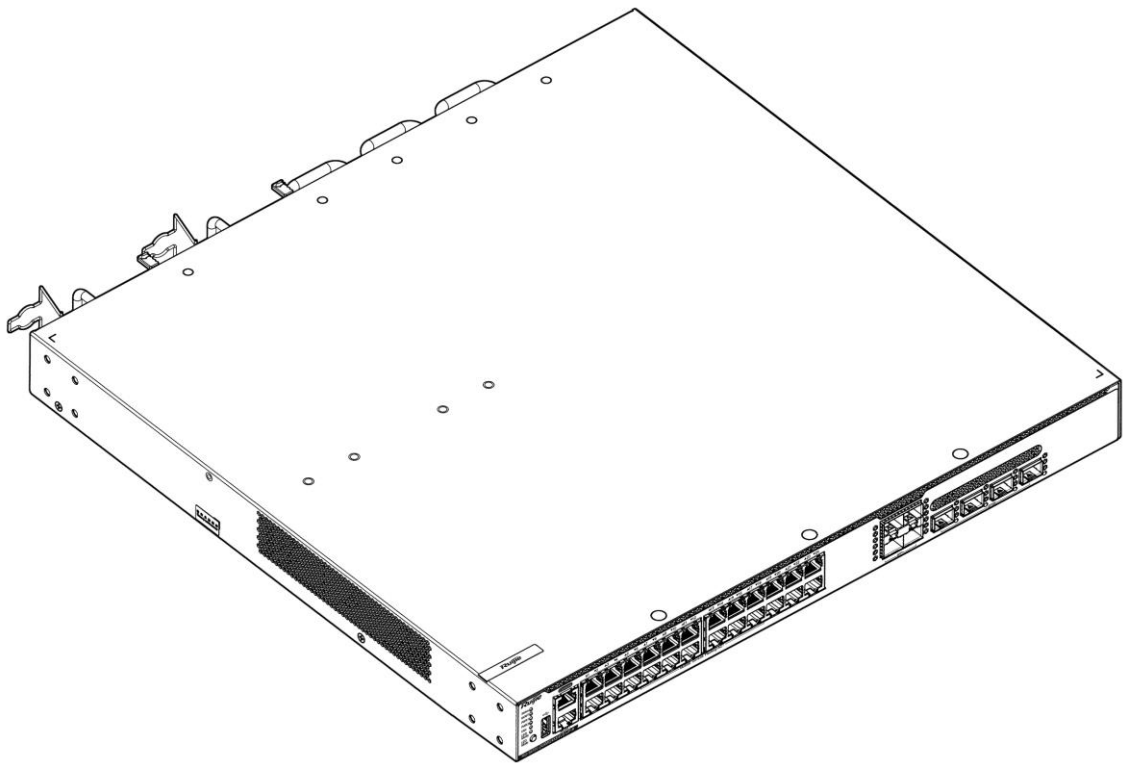
**⚠ Warning**

This device is not suitable for use in places where children may be present.

**Appearance**

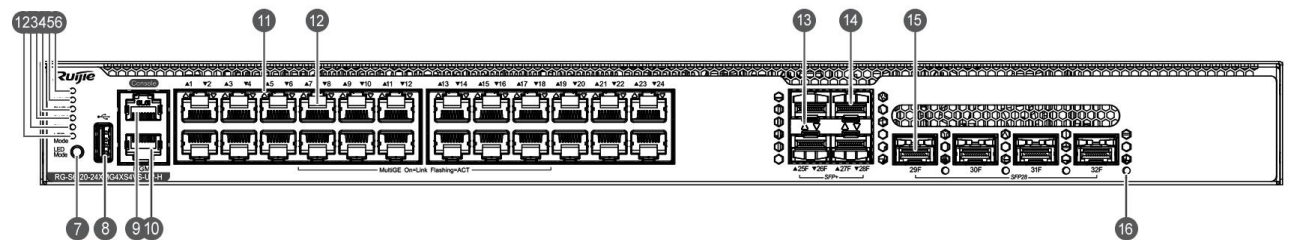
On the front panel of the RG-CS86-24XMG4XS4VS-UPD Ethernet switch, there are 24 multi-GE electrical ports (100ME/1GE/2.5GE/5GE/10GE), with each electrical port supporting IEEE 802.3bt Type 4 (90 W) PoE, four 10GE optical ports, four 25GE optical ports, one management Ethernet electrical port (MGMT), one USB port, and one console port (Console). On the rear panel, there are two power module slots and three fan module slots. The following figures show the product appearance.

**Figure 1-11 Appearance of an RG-CS86-24XMG4XS4VS-UPD Switch**



**Front Panel**

**Figure 1-12 Front Panel of an RG-CS86-24XMG4XS4VS-UPD Switch**

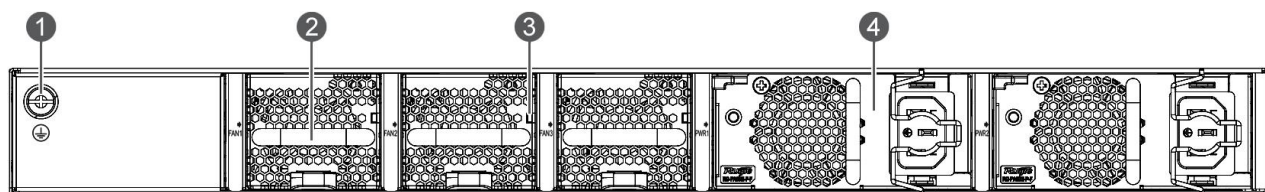


Note	1. LED mode LED	9. Console port
	2. Fan status LED (FAN)	10. Ethernet port for management (MGMT)
	3. PWR2 status LED	11. Multi-GE electrical port LED
	4. PWR1 status LED	12. 100ME/1GE/2.5GE/5GE/10GE multi-GE electrical ports
	5. Management port status LED	13. SFP+ port LED
	6. System status LED	14. SFP+ port
	7. LED mode button	15. SFP28 port
	8. USB port	16. SFP28 port LED

**Rear Panel**



**Figure 1-13 Rear Panel of an RG-CS86-24XMG4XS4VS-UPD Switch**



Note	1. Grounding stud	3. Fan module status LED
	2. Fan module slot	4. Power module slot

**External Ports**

The RG-CS86-24XMG4XS4VS-UPD switch provides the following ports:

- USB port: The USB port is the interface into which you plug your USB storage device for online upgrade or log storage.

**Note**

To ensure data security and prevent damage to your device, please use USB flash drives of well-known brands and good quality. The USB port is compatible with most USB controllers and may not recognize some models of USB flash drives.

**Note**

The RG-CS86-24XMG4XS4VS-UPD switch supports configuration, maintenance, management, program loading and system debugging through console.

- Console port: The console port is an RS-232 port that uses an RJ45 connector. The console port is used to connect a PC directly to the management system for debugging, configuration, maintenance, management and program loading.
- Management port: The management port is an out-of-band Ethernet port that uses an RJ45 connector. You can manage and maintain the device remotely by connecting the management port to the Ethernet port of a PC with an Ethernet cable.
- Multi-GE electrical ports: 24 100ME/1GE/2.5GE/5GE/10GE multi-GE electrical ports. Each port supports IEEE 802.3bt Type 4 (90 W) PoE.
- SFP+ ports: four 10G/1G SFP+ ports, supporting optical modules and DAC cable, and compatible with the 1000BASE-X mode.
- SFP28 ports: four 25GE/10GE SFP28 ports, supporting 25GE optical module, and 10GE optical module or DAC cable, but not 25GE copper cable. Four 25GE/10GE SFP28 ports multi-GE switches must operate at the same rate (25Gbps or 10Gbps). Operation at mixed rates is not supported.

**Note**

To ensure the traffic forwarding performance, these four SFP28 ports are recommended to operate at 25 Gbps.

**LEDs**

LED	Panel ID	Color	Status
System Status	SYS	Off	System is not powered on.

LED		Blinking Green (3 Hz)	System is being initialized. Continuous blinking indicates a fault.
		Blinking Green (10 Hz)	System is being located, and can be remotely turned on or off by an O&M engineer.
		Solid green	System is operating normally.
		Solid yellow	Temperature at the air intake and exhaust vents exceeds the threshold.
		Solid red	Temperature at air inlets and outlets exceeds the threshold. System is faulty.
Power Module Status LED	PWR1/PWR 2	Off	The power module is not seated.
		Solid green	The power module is seated and providing power to the switch.
		Solid yellow	The model of the power module is not supported or cannot be read.
		Solid red	The redundant power module is not functioning properly or not connected to the AC power cord.
System Fan Module Status LED	FAN	Solid green	All fan modules are seated and functioning properly.
		Solid red	One fan module is faulty. Fan module model is not supported. One fan module is not seated.
PoE LED	PoE	Solid green	The LED indicates the switching status.
		Solid yellow	The LED indicates the PoE power supply status.
MGMT Port Status LED	MGMT	Off	No link is established on this port.
		Green	A 1000 Mbps link is established on this port.
		Blinking green	The port is sending and receiving traffic at 1000 Mbps.
		Yellow	A 100/10 Mbps link is established on this port.
		Blinking yellow	The port is sending and receiving traffic at 100/10 Mbps.
RJ45 port LED	1-24	Off	No link is established on this port.
		Solid green	A 1G/2.5G/5G/10G link is established on this port.

		Blinking green	The port is sending or receiving traffic at 1/2.5/5/10 Gbps.
		Solid yellow	A 100 Mbps link is established on this port.
		Blinking yellow	The port is sending and receiving traffic at 100 Mbps.
PoE Status LED	1-24	Off	PoE is disabled.
		Solid green	PoE is enabled.
		Solid yellow	The PoE port is overloaded or faulty.
SFP+ Port Status LED	25F-28F	Off	No link is established on this port.
		Solid green	A 10/1 Gbps link is established on this port.
		Blinking green	The port is sending and receiving traffic at 1/10 Gbps.
SFP28 Port Status LED	29F-32F	Off	No link is established on this port.
		Solid green	A 25/10 Gbps link is established on this port.
		Blinking green	The port is sending and receiving traffic at 25/10 Gbps.

#### LED Mode Button

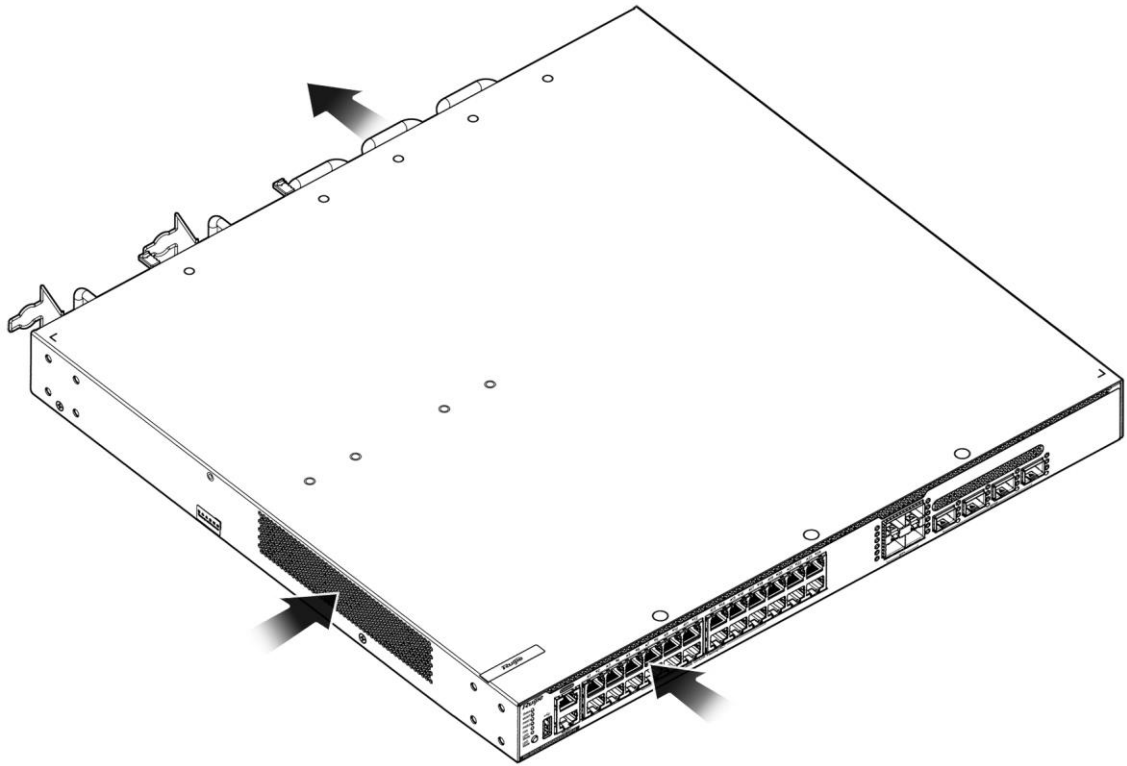
The LED Mode button is used to switch the LED mode. The green LED Mode indicator indicates the switching status. Press the LED Mode button, and the LED Mode indicator will turn yellow, indicating the PoE status. Press the LED Mode button again, the indicator switches to indicating the switching status.

If you want to switch the LED mode, press the button for over two seconds.

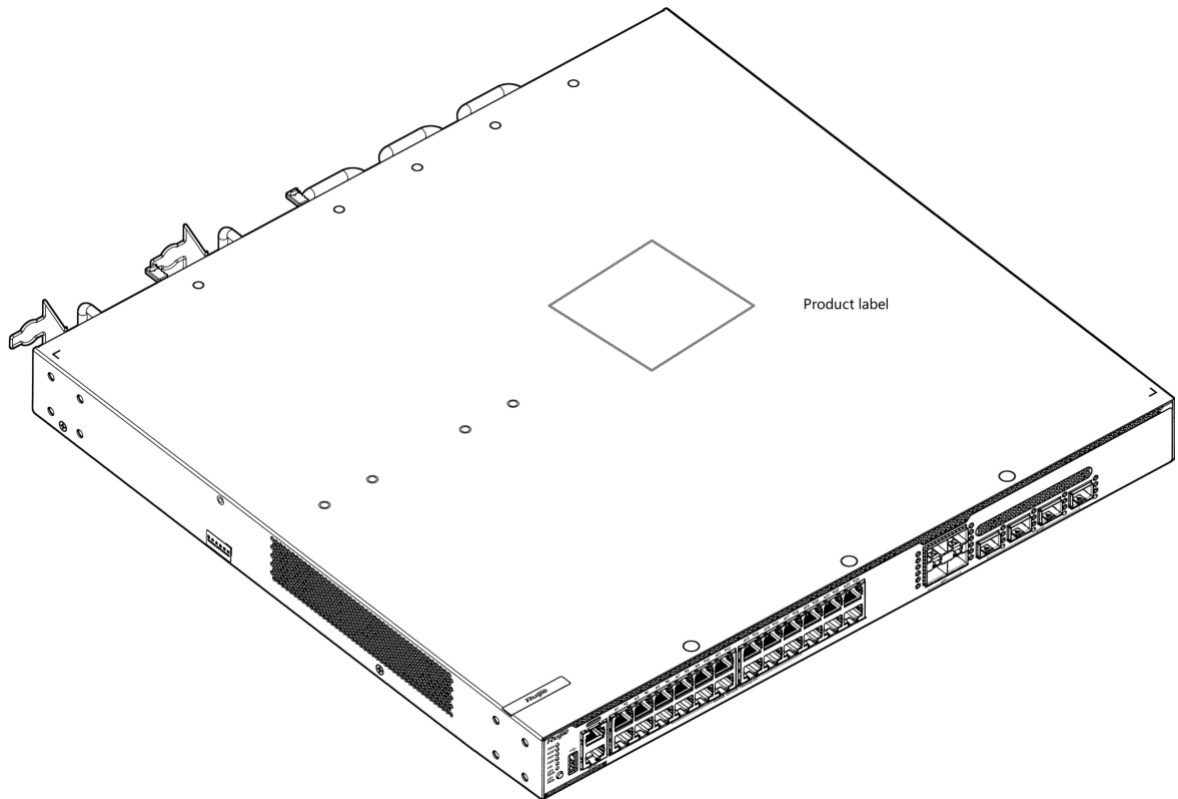
#### Heat Dissipation

RG-CS86-24XMG4XS4VS-UPD adopts the left-to-rear and front-to-rear airflow design to ensure normal operation in the specified environment. A minimum clearance of 100 mm (3.94 in.) must be maintained around the device to ensure proper ventilation. The following figure shows the airflow direction.

**Figure 1-14 Airflow Direction**



**Figure 1-15 RG-CS86-24XMG4XS4VS-UPD Product information label**



## 1.4 RG-CS86-12XMG4VS-UP

### Specifications

Model	RG-CS86-12XMG4VS-UP
CPU	ARM processor, 1.25 GHz clock rate
BOOT ROM	16 MB
Flash Memory	1 GB
RAM	1GB DDR4, 32-bit bandwidth and 4-bit ECC
Expansion Module Slot	Not supported
Fan Module Slot	Fixed fan modules
Power Module Slot	Built-in Power Supply AC Input Rated voltage range: 100 V AC to 240 V AC Maximum voltage range: 90 V AC to 264 V AC Frequency: 50/60 Hz Rated current per circuit: 6 A
Max. Power Consumption	< 120 W
Supported Optical Module Types	For details, see Appendix B. The supported optical module types may update without prior notice. Please contact Ruijie Networks for details.
PoE	All RJ45 ports comply with the IEEE 802.3bt PoE standard. Each port can provide up to 90 W of power through PoE. The maximum power is subject to the actual power supply. The maximum number of PoE devices supported by the switch is determined by the PoE output power of the switch and the actual power of PoE devices.
POE Available Power	370 W
PoE Power Cable Pairs	Four pairs (1-2, 3-6, 4-5 and 7-8 pairs)
Temperature Alarm	Support temperature alarm and over-temperature protection.
EMC Certification	IEC62368-1

Safety Regulation Compliance	IEC62368-1
Altitude	0-5000 m (0-16404 ft.)
Operating Temperature	0°C to 45°C (32°F to 113 °F) at a height below 3000 m (9842 ft.) above the sea level Description Altitude 3000 m (9842 ft.) to 5000 m (16404 ft): The maximum temperature decreases by 1°C (1.8°F) each time the altitude increases by 220 m (721 ft).
Storage Temperature	-40°C to +70°C (-40°F to +158°F)
Operating Humidity	10% to 90% RH (non-condensing)
Storage Humidity	5% to 95% RH (non-condensing)
Weight	3.65 kg (8.82 lbs.)
Dimensions (W x D x H)	442 mm x 220 mm x 43.6 mm (17.40 in. x 29.92 in. x 6.89 in.)

**⚠ Caution**

- RG-CS86-12XMG4VS-UP is a Class A product. In a domestic environment, this product may cause radio interference. In this case, users are advised to take proper measures against the interference.



- Electric shock hazard ! The fuse is in the neutral, and that the mains shall be disconnected to de-energize the phase conductors.

**! Warning**

This device is not suitable for use in places where children may be present.

**Appearance**

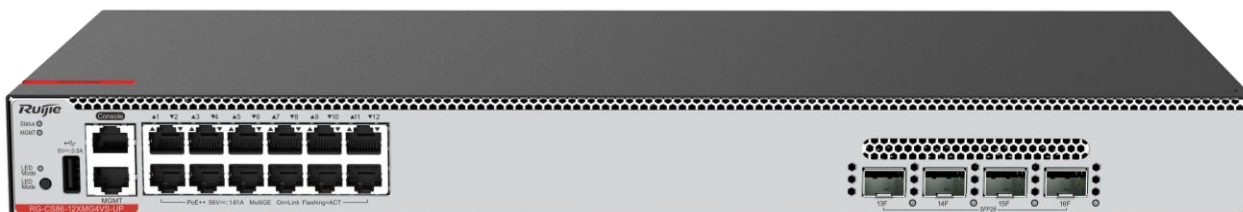
The front panel of the RG-CS86-12MG4VS-UP Ethernet switch is provided with 12 multi-GE electrical ports (100ME/1GE/2.5GE/5GE/10GE), with each port supporting IEEE 802.3bt Type 4 (90 W) PoE, four 25G optical ports, one management Ethernet electrical port (MGMT), one USB port, and one console port (Console). The following figures show the product appearance.

LED	Panel ID	Color	Status
System Status LED	SYS	Off	System is not powered on.
		Blinking green (3 Hz)	System is being initialized. Continuous blinking indicates a fault.

		Blinking green (10 Hz)	System is being located.
		Solid green	System is operating normally.
		Solid yellow	Temperature at the air intake and exhaust vents exceeds the threshold.
		Solid red	Temperature at air inlets and outlets exceeds the threshold. System is faulty.
Power Module Status LED	PWR1/PWR2	Off	The power module is not seated.
		Solid green	The power module is seated and providing power to the switch.
		Solid yellow	The model of the power module is not supported or cannot be read.
		Solid red	The redundant power module is not functioning properly or not connected to the AC power cord.
System Fan Module Status LED	FAN	Solid green	All fan modules are seated and functioning properly.
		Solid red	One fan module is faulty. Fan module model is not supported. One fan module is not seated.
PoE LED	PoE	Solid green	The LED indicates the switching status.
		Solid yellow	The LED indicates the PoE power supply status.
MGMT Port Status LED	MGMT	Off	No link is established on this port.
		Green	A 1000 Mbps link is established on this port.
		Blinking green	The port is sending and receiving traffic at 1000 Mbps.
		Yellow	A 100/10 Mbps link is established on this port.
		Blinking yellow	The port is sending and receiving traffic at 100/10 Mbps.
RJ45 port LED	1-12	Off	No link is established on this port.
		Solid green	A 1 Gbps/2.5 Gbps/5 Gbps/10 Gbps link is established on this port.
		Blinking green	The port is sending or receiving traffic at 1/2.5/5 Gbps.
		Solid yellow	A 100 Mbps link is established on this port.

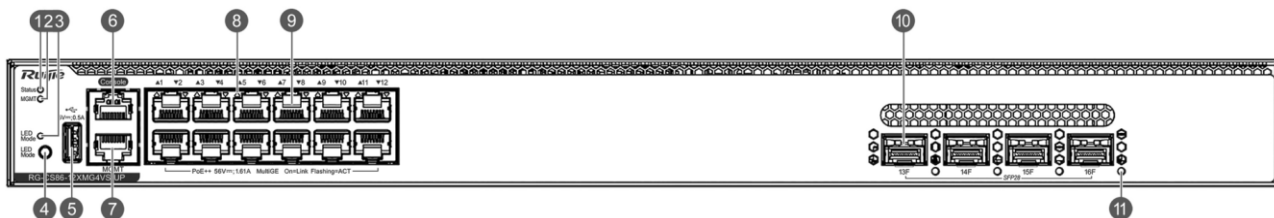
		Blinking yellow	The port is sending and receiving traffic at 100 Mbps.
PoE Status LED	1-12	Off	PoE is disabled.
		Solid green	PoE is enabled.
		Solid yellow	The PoE port is overloaded or faulty.
SFP28 Port Status LED	13F-16F	Off	No link is established on this port.
		Solid green	A 25/10 Gbps link is established on this port.
		Blinking green	The port is sending and receiving traffic at 25/10 Gbps.

Figure 1-16 Appearance of an RG-CS86-12MG4VS-UP Switch



Front Panel

Figure 1-17 Front Panel of an RG-CS86-12XMG4VS-UP Switch

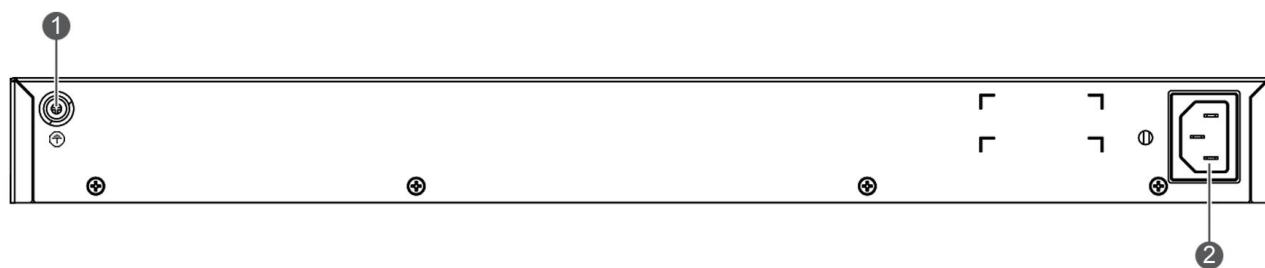


Note	1. System status LED	7. Ethernet port for management
	2. MGMT interface status LED	8. Electrical port LED
	3. LED mode LED	9. 100ME/1GE/2.5GE/5GE multi-GE electrical ports
	4. LED mode button	10. SFP28 port
	5. USB port	11. SFP28 port LED
	6. Console port	

Rear Panel



**Figure 1-18 Rear Panel of an RG-CS86-12XMG4VS-UP Switch**



Note      1. Grounding stud  
              2. AC power connector

**External Ports**

The RG-CS86-12XMG4VS-UP switch provides the following ports:

- USB port: The USB port is the interface into which you plug your USB storage device for online upgrade or log storage.

**i Note**

To ensure data security and prevent damage to your device, please use USB flash drives of well-known brands and good quality. The USB port is compatible with most USB controllers and may not recognize some models of USB flash drives.

**i Note**

The RG-CS86-12XMG4VS-UP switch supports configuration, maintenance, management, program loading and system debugging through console.

- Console port: The console port is an RS-232 port that uses an RJ45 connector. The console port is used to connect a PC directly to the management system for debugging, configuration, maintenance, management and program loading.
- Management port: The management port is an out-of-band Ethernet port that uses an RJ45 connector. You can manage and maintain the device remotely by connecting the management port to the Ethernet port of a PC with an Ethernet cable.
- Multi-GE electrical ports: 12 100ME/1GE/2.5GE/5GE/10GE multi-GE electrical ports. Each port supports IEEE 802.3bt Type 4 (90 W) PoE.
- SFP28 ports: four 25GE/10GE SFP28 ports, supporting 25GE optical module, and 10GE optical module or DAC cable, but not 25GE copper cable. Four 25GE/10GE SFP28 ports multi-GE switches must operate at the same rate (25Gbps or 10Gbps). Operation at mixed rates is not supported.

**i Note**

To ensure the traffic forwarding performance, these four SFP28 ports are recommended to operate at 25 Gbps.

**LEDs**

**LED Mode Button**

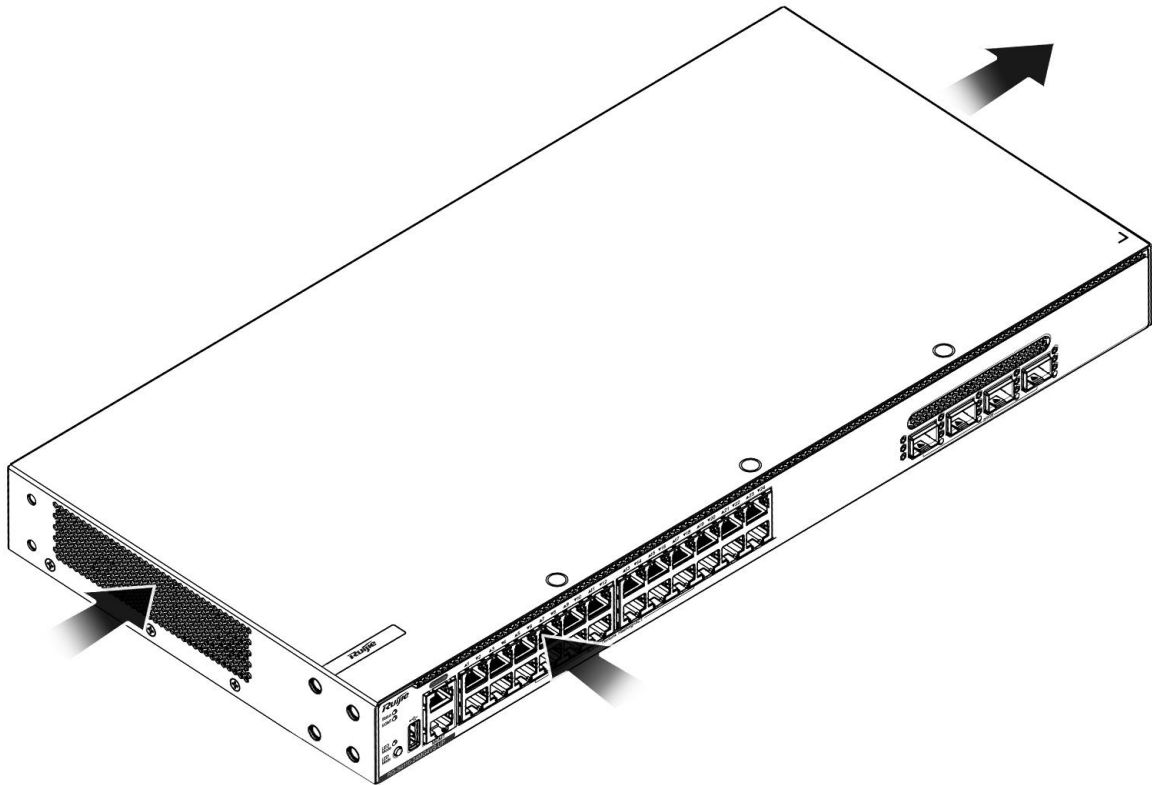
The LED Mode button is used to switch the LED mode. The green LED Mode indicator indicates the switching status. Press the LED Mode button, and the LED Mode indicator will turn yellow, indicating the PoE status. Press the LED Mode button again, the indicator switches to indicating the switching status.

If you want to switch the LED mode, press the button for over two seconds.

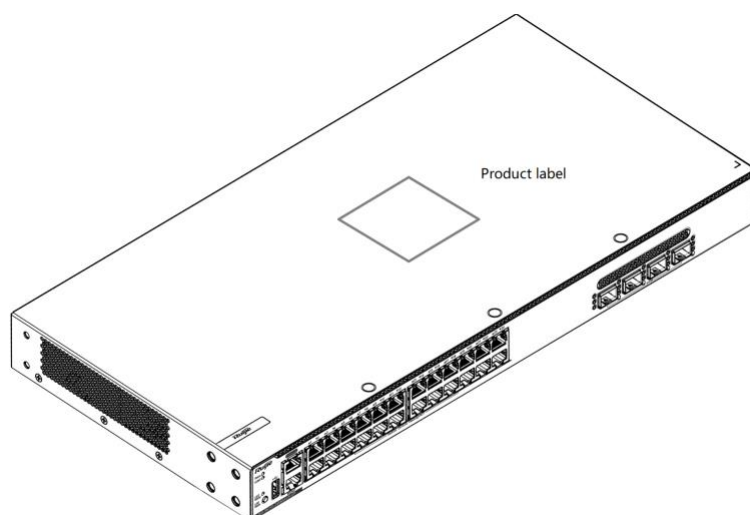
### Heat Dissipation

The RG-CS86-12XMG4VS-UP switch adopts a left-to-right and front-to-right airflow design to ensure that the switch works properly in the specified environment. A minimum clearance of 100 mm (3.94 in.) must be maintained around the device to ensure proper ventilation. The following figure shows the airflow direction.

**Figure 1-19 Airflow Direction**



**Figure 1-20 RG-CS86-12XMG4VS-UP Product information label**



## 1.5 Module

### 1.5.1 RG-PA600I-P-F Power Module

RG-CS86-48MG4VS2QXS-UPD, RG-CS86-24XMG4XS4VS-UPD support RG-PA600I-P-F swappable power module. The RG-PA600I-P-F is an AC module (AC/HVDC input and DC output) providing an output voltage of 56 V and an output power of up to 600 W.

**Note**

- The switch can be powered on by either one power module or dual power modules. If both power modules are used, the switch works in the power redundancy mode. The system supports 1+1 power redundancy when the PoE load power is less than 450 W for RG-CS86-24XMG4XS4VS-UPD, and 400 W for RG-CS86-48MG4VS2QXS-UPD.
- At least one power module is required. If any slot is unoccupied, install a filler panel to enable proper airflow.

**Specifications**

Item	Specification
Model	RG-PA600I-P-F
Switch Model	RG-CS86-48MG4VS2QXS-UPD, RG-CS86-24XMG4XS4VS-UPD,
Rated Input Voltage Range	AC Input: 100V AC to 240 V AC, 50/60 Hz HVDC Input: 240 V DC
Maximum Input Voltage Range	AC Input: 90V AC to 264 V AC, 47/63 Hz HVDC Input: 192 V DC to 288 V DC
Maximum Input Current	8 A
Output Voltage	56 V

Maximum Output Current	10.72A
Maximum Output Power	600 W
PoE Available Power	PoE available power is subject to the product model (see data sheet for details).
Ground Leakage Current	≤3.5 mA
Dimensions (W x D x H)	196 mm x 90 mm x 40 mm (7.72 in. x 3.54 in. x 1.57 in.)
Weight	0.9 kg (1.98 lbs.)
Operating Temperature	-10°C to +55°C (-40°F to 158°F)
Storage Temperature	-40°C to 70°C (-40°F to 158°F)
Operating Humidity	5% to 95% RH (non-condensing)
Storage Humidity	5% to 95% RH (non-condensing)
Operating Altitude	0 to 5000 m (0-16404 ft.)

**Features**

Feature	Description
Conformal Coating	Moisture-proof, salt spray-proof, mold-proof, insulation-proof and leak-proof.
Protection	Undervoltage protection, output overcurrent protection, output overvoltage protection and output short circuit protection.
I2C Communication	The switch can communicate with the power module through I2C.
Power Redundancy	The system supports 1+1 power redundancy when the PoE load power is less than 450 W for RG-CS86-24XMG4XS4VS-UPD, and 400 W for RG-CS86-48MG4VS2QXS-UPD. Dual power modules are connected in parallel for current sharing.
Hot Swapping	In the power redundancy mode, the power module can be replaced when the system is powered on.
Alarming	When a power fault occurs, the output status LED turns off.

**LEDs**

Name	Status	Description
Output Status LED	Off	The power module is not connected to a power

		cord.
	Solid red	A power output error occurred, including fan fault, output short-circuit, output overcurrent protection, output overvoltage protection, power supply failure and overheat protection.
	Solid green	The power module is functioning normally.

**Note**

- When inserting the power cord, please fasten the anti-loose tripping on the power cord correctly to prevent the power cord from loosening.
- The power cord should be connected to AC socket with ground connection.

### 1.5.2 RG-PA1000I-P-F Power Module

RG-CS86-48MG4VS2QXS-UPD, RG-CS86-24XMG4XS4VS-UPD support RG-PA1000I-P-F swappable power module. The RG-PA1000I-P-F is an AC module (AC/HVDC input and DC output) providing an output voltage of 56 V and an output power of up to 1000 W.

**Note**

- The switch can be powered on by either one power module or dual power modules. If both power modules are used, the switch works in the power redundancy mode. The system supports 1+1 power redundancy when the PoE load power is less than 760 W for RG-CS86-24XMG4XS4VS-UPD, and 710 W for RG-CS86-48MG4VS2QXS-UPD.
- At least one power module is required. If any slot is unoccupied, install a filler panel to enable proper airflow.

**Specifications**

Item	Specification
Model	RG-PA1000I-P-F
Switch Model	RG-CS86-48MG4VS2QXS-UPD, RG-CS86-24XMG4XS4VS-UPD,
Rated Input Voltage Range	AC Input: 100V AC to 240 V AC, 50/60 Hz HVDC Input: 240 V DC
Maximum Input Voltage Range	AC Input: 90V AC to 264 V AC, 47/63 Hz HVDC Input: 192 V DC to 288 V DC
Maximum Input Current	12 A (Input Voltage: 100 V AC) 8 A (Input Voltage: 200 V AC)
Output Voltage	56 V
Maximum Output Current	17.86 A (Input Voltage: 176 V AC to 290 V AC or 190 V DC to 290 V DC) 16.61 A (Input Voltage: 90 V AC to 176 V AC, 176 V AC not included)
Maximum Output Power	1000 W (Input Voltage: 176 V AC to 290 V AC or 190 V DC to 290 V DC) 930 W (Input Voltage: 90 V AC to 176 V AC, 176 V AC not included)

PoE Available Power	PoE available power is subject to the product model (see data sheet for details).
Ground Leakage Current	≤3.5 mA
Dimensions (W x D x H)	196 mm x 90 mm x 40 mm (7.72 in. x 3.54 in. x 1.57 in.)
Weight	1 kg (1.98 lbs.)
Operating Temperature	-10°C to +55°C (-40°F to 158°F)
Storage Temperature	-40°C to 70°C (-40°F to 158°F)
Operating Humidity	5% to 95% RH (non-condensing)
Storage Humidity	5% to 95% RH (non-condensing)
Operating Altitude	0 to 5000 m (0-16404 ft.)

**Features**

Feature	Description
Conformal Coating	Moisture-proof, salt spray-proof, mold-proof, insulation-proof and leak-proof.
Protection	Undervoltage protection, output overcurrent protection, output overvoltage protection and output short circuit protection.
I2C Communication	The switch can communicate with the power module through I2C.
Power Redundancy	The system supports 1+1 power redundancy when the PoE load power is less than 760 W for RG-CS86-24XMG4XS4VS-UPD, and 710 W for RG-CS86-48MG4VS2QXS-UPD. Dual power modules are connected in parallel for current sharing.
Hot Swapping	In the power redundancy mode, the power module can be replaced when the system is powered on.
Alarming	When a power fault occurs, the output status LED turns off.

**LEDs**

Name	Status	Description
Output Status LED	Off	The power module is not connected to a power cord.
	Solid red	A power output error occurred, including fan fault, output short-circuit, output overcurrent protection, output overvoltage

		protection, power supply failure and overheat protection.
	Solid green	The power module is functioning normally.

**i Note**

- When inserting the power cord, please fasten the anti-loose tripping on the power cord correctly to prevent the power cord from loosening.
  - The power cord should be connected to a powerlet with ground connection.
-

# 2 Preparing for Installation

## 2.1 Safety Precautions

---

**i Note**

- To avoid personal injury and device damage, carefully read the safety precautions before you install the device.
  - The following safety precautions may not cover all possible dangers.
- 

### 2.1.1 Install Safety

- Keep the chassis clean, and free from any dust.
- Do not place the device in walking areas.
- During the installation and maintenance, do not wear loose clothes, ornaments, or any other things that may be hooked by the chassis.
- Cut off all power supplies and unplug all power cords before moving or handling the device.

### 2.1.2 Handling Safety

- Avoid moving the device frequently.
  - Cut off all power supplies and unplug all power cords before handling the device.
  - Keep balance and prevent personal injuries when handling the device.
- 

**⚠ Caution**

- When handling the device, please do not grab the handle of the power module or fan module. The handle is not designed to carry the weight of the whole device. Grabbing the handle can cause device damage or even injury to your body.
  - Before handling the device, remove the expansion module, fan module, and power module to reduce the weight.
  - The device must be installed or operated in a location where movement is restricted.
- 

### 2.1.3 Electric Safety

- Observe local regulations and specifications during electric operations. Only personnel with relevant qualifications can perform such operations.
- Before installing the device, check whether there are hidden risks in the operating environment of the device. For example, check whether the power socket is grounded and whether the ground is wet.
- Be sure to know the location of the indoor emergency power supply switch before installing the device. When an accident occurs, immediately cut off all power supplies.
- Do not maintain the device by yourself when the device is powered on.
- Make sure that the device is powered off when you cut off the power supply.
- Do not place the device in a wet position, and keep the device away from liquid.



**⚠ Caution**

- Improper or incorrect electric operations may cause a fire, electric shock, and other accidents, and lead to severe and fatal personal injury and device damage.
  - Direct or indirect contact with high voltage or mains power supply through wet objects may cause fatal dangers.
  - The device is powered by more than one power source. Disconnect all power sources before shutting down the device.
  - If a power supply system is equipped with a leakage protector (also referred to as leakage current switch or leakage current breaker), the rated leakage action current of each leakage protector must be greater than twice the theoretical maximum leakage current of all the power supplies in the system. For example, if a system is equipped with 16 identical power supplies and the leakage current of each power supply is equal to or less than 1.75 mA, the leakage current of the system totals 28 mA. A leakage protector with 30 mA rated action current supports less than nine power supplies (that is, Action current of the leakage protector/2/Maximum leakage current of each power supply =  $30/2/1.75 \approx 8.57$ ). In other words, the leakage protector with 30 mA rated action current supports no more than eight power supplies. In this case, the 16 power supplies in the system require at least two leakage protectors with 30 mA rated action current and each leakage protector supports eight power supplies. If power supplies in a system differ in models, the rated leakage action current of each leakage protector divided by two is greater than the sum of maximum leakage currents of all the power supplies. The rated leakage non-action current of a leakage protector shall be 50% of the leakage action current. Take a leakage protector with 30 mA rated leakage action current as an example. The rated leakage non-action current shall be 15 mA. When the leakage current is below 15 mA, the protector shall not act. Otherwise, misoperation may easily occur due to high sensitivity and thus the leakage protector trips, devices are powered off, and services are interrupted.
  - To guarantee personal safety, the rated leakage action current of each leakage protector in the system must be equal to or less than 30 mA (human body safety current is 30 mA). When twice of the total leakage current of the system is greater than <http://baike.baidu.com/item/安全电流>, 30 mA, the system must be equipped with two or more leakage protectors.
  - For the leakage current value of each power supply model, see the power supply model specifications in Chapter 1.
- 

## 2.1.4 Electrostatic Discharge Safety

Although a great deal of consideration has been given and a variety of measures have been taken to prevent static electricity, when the static electricity exceeds a certain value, it will damage the circuit and device. In the communication networks to which the device is connected, the electrostatic induction of the device mainly comes from outdoor high-voltage power lines, lightning and other external electric fields, indoor floor materials and the internal structure of the device.

To prevent damage caused by static electricity, you must pay attention to the following:

- Properly ground the device and floor.
- Keep the indoor installation environment clean and free of dust.
- Maintain appropriate humidity conditions.
- Before installing a pluggable module, wear an ESD wrist strap and make sure that it is well grounded.
- Do not touch the components and printed circuit board of the module directly with your hands.
- Use an ESD bag to keep the module.
- Avoid contact between the clothing and other items with the printed circuit board. The ESD wrist strap can only prevent damage to the printed circuit board caused by static electricity on the body. Static electricity on clothing cannot be prevented.

## 2.1.5 Laser Safety

Among the modules supported by the device, many optical modules are Class I laser products.

Precautions

- When an optical transceiver is working, ensure that its port is connected to an optical fiber or covered by a dust cap to keep out dust and prevent it from burning your eyes.
- Do not stare at any fiber port.

---

### **Caution**

Do not approach or look into any optical port under any circumstances. This may cause permanent damage to your eyes.

---

## 2.2 Installation Site Requirements

The device must be used indoors. To ensure the normal operation and prolonged service life of the device, the installation site must meet the following requirements.

### 2.2.1 Cabinet Installation Requirements

If the device is installed inside a cabinet, the following conditions must be met:

- The device must be installed in an open cabinet. If the device is installed in a closed cabinet, ensure that the cabinet has proper ventilation and heat dissipation.
- The cabinet must be sturdy enough to support the weight of the device and its accessories.
- You are advised to install the device into a standard cabinet and maintain a proper clearance around the air vents for heat dissipation.
- The cabinet must be properly grounded.

### 2.2.2 Ventilation Requirements

Reserve sufficient space at the rear end of the air vents to ensure proper heat dissipation. Maintain a minimum clearance of 200 mm (7.87 in.) around the device for air circulation. After various cables are connected, bundle the cables or place them in the patch panel to avoid blocking air inlets. Dust the device every three months to avoid blocking the ventilation openings on the housing.

### 2.2.3 Temperature and Humidity Requirements

To ensure the normal operation and prolonged service life of the device, maintain an appropriate temperature and humidity in the machine room. The machine room with too high or too low temperature and humidity for a long period may damage the switch.

- In an environment with high humidity, the insulating material may have poor insulation or even leak electricity. Sometimes high humidity may cause changes in the mechanical properties and causes rusting of metal parts.
- In an environment with low relative humidity, static electricity is prone to occur and damage the internal circuits of the switch.
- Too high temperatures can accelerate the aging of insulation materials, greatly reducing the reliability of the switch and severely affecting its service life.

The table below lists the ambient temperature and humidity requirements of the device.

Model	Operating Temperature	Operating Humidity
RG-CS86-24MG4VS-UP	0°C to 45°C (32°F to 113°F)	10% to 90% (non-condensing)
RG-CS86-48MG4VS2QXS-UPD	0°C to 45°C (32°F to 113°F)	10% to 90% (non-condensing)
RG-CS86-24XMG4XS4VS-UPD	0°C to 45°C (32°F to 113°F)	10% to 90% (non-condensing)
RG-CS86-12XMG4VS-UP	0°C to 45°C (32°F to 113°F)	10% to 90% (non-condensing)

**Note**

The ambient temperature and humidity of the device are measured at the point that is 1.5 m (59.06 in.) above the floor and 0.4 m (15.75 in.) before the rack when there is no protective plate in front or at the back of the rack.

### 2.2.4 Cleanliness Requirements

Dust poses a major threat to the device. The indoor dust takes on a positive or negative static electric charge when falling on the device, causing poor contact of the metallic joint. Such electrostatic adhesion may occur more easily when the relative humidity is low, not only affecting the service life of the device, but also causing communication failure. Table 2-1 lists the requirements for the dust content and granularity in the machine room.

Dust	Unit	Content
Dust particles (diameter ≥ 0.5 μm)	Particles/ m <sup>3</sup>	≤3.5×10 <sup>6</sup>
Dust particles (diameter ≥ 5 μm)	Particles/ m <sup>3</sup>	≤3×10 <sup>4</sup>

Apart from dust, the salt, acid, and sulfide in the air in the machine room must meet strict requirements. These harmful substances will accelerate metal corrosion and component aging. Therefore, the machine room should be properly protected against the intrusion of harmful gases, such as sulfur dioxide, hydrogen sulfide, nitrogen dioxide, and chlorine gas.

Gas	Average (mg/m <sup>3</sup> )	Maximum (mg/m <sup>3</sup> )
Sulfur dioxide (SO <sub>2</sub> )	0.3	1.0
Hydrogen sulfide (H <sub>2</sub> S)	0.1	0.5
Nitrogen dioxide (NO <sub>2</sub> )	0.5	1.0
Chlorine gas (Cl <sub>2</sub> )	0.1	0.3

**Note**

Average refers to the average value of harmful gases measured in one week. Maximum refers to the upper limit of a harmful gas measured in one week for up to 30 minutes every day.

## 2.2.5 Grounding Requirements

A proper grounding system is the basis for stable and reliable operation of the device. It is indispensable for preventing lightning strikes and interference. Carefully check the grounding conditions at the installation site according to the grounding specifications, and complete grounding properly based on the actual situation.

### Secure Grounding

Ensure that the device is securely grounded using a yellow/green grounding cable when the device uses the AC power supply or high-voltage DC power supply. Otherwise, an electric shock may occur when a grounding error occurs to the high-voltage circuit inside the device.

#### Caution

The building should provide a protective ground connection to ensure that the device is connected to a protective earth.

### Lightning Protection

The lightning protection system of facilities is standalone, and is composed of a lightning rod, a down conductor, and a connector connected to the grounding system. The grounding system is usually used for power reference grounding and safety grounding of the cabinet. Lightning discharge grounding is required only for facilities and is not required for the device.

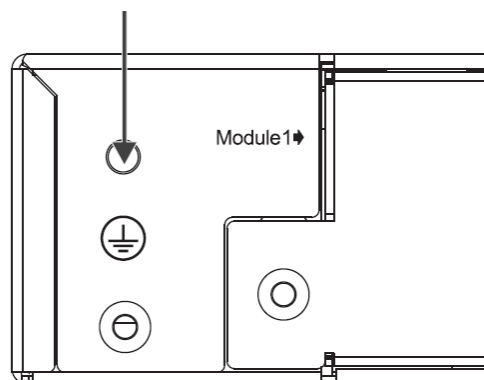
#### Note

For lightning protection, see Appendix C.

### EMC Grounding

Grounding required for electromagnetic compatibility includes shielded grounding, filter grounding, noise and interference suppression, and level reference, which contribute to the overall grounding requirements. The grounding resistance should be smaller than 1 ohm. There is a grounding lug in the lower right corner at the back of the chassis and is marked with a conspicuous label.

**Figure 2-1 Grounding of an RG-CS86 Series Switch**



## 2.2.6 EMI Requirement

All interference sources, either from outside or inside of the device or application system, affect the device by capacitive coupling, inductive coupling, or electromagnetic waves. Electromagnetic interference (EMI) occurs due to electromagnetic radiation or conduction, depending on the transmission path. When the energy, often RF energy, from a component arrives at a sensitive component through the space, the energy is known as

radiated interference. The interference source can be both a part of the interfered system and a completely electrically isolated unit. Conduction interference occurs when interference is transferred from one unit to another unit through cables, which are usually electromagnetic wires or signal cables connected between the source and the sensor. Conducted interference often affects the power supply of the equipment, but can be controlled by a filter. Radiated interference may affect any signal path in the equipment, and is difficult to shield.

- Take interference prevention measures for the power supply system.
- Keep the device far away from grounding or lightning protection devices for power equipment.
- Keep the device far away from high-frequency current devices such as high-power radio transmitting station and radar launcher.
- Take electromagnetic shielding measures when necessary.

## 2.3 Fiber-Optic Cable Connection Requirements

Make sure that the models of optical transceivers and optical cables match with SFP ports. The transmitting port on the local device should be connected to the receiving port on the peer device and vice versa.

## 2.4 Tools

Common Tools	Phillips screwdriver, related Ethernet and fiber-optic cables, bolts, diagonal pliers, cable ties
Special Tools	ESD gloves, wire stripper, crimping plier, RJ45 crimping plier, and wire cutter
Cleaning Tools	Dust-free paper, fiber end-face microscope
Meters	Multimeter, bit error rate tester (BERT), optical power meter

**Note**

The RG-CS86 series multi-GE switches are delivered without a tool kit. The tool kit is customer-supplied.

## 2.5 Unpacking the Switch

### Package Contents

Chassis Kit	Switch, yellow and green grounding cable, Quick Start Guide and Package Contents
Module Kit	Modules, Quick Start Guide and Package Contents

**Note**

The above is the general packet contents. The actual delivery is subject to the order contract. Check your goods carefully against the order contract. If you have any questions, please contact the distributor.

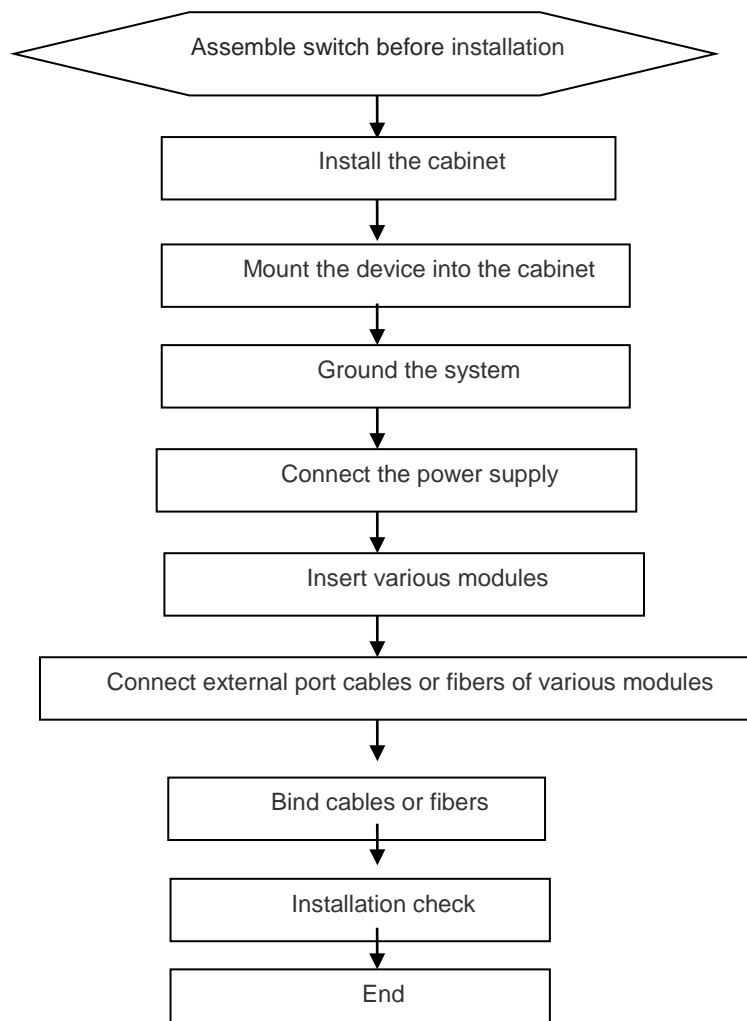
# 3 Installing the Switch

The RG-CS86 series multi-GE switches must be installed indoors.

**Note**

Before installing the device, make sure that you have carefully read and met the requirements specified in Chapter 2.

## 3.1 Installation Procedure



## 3.2 Before You Begin

Carefully plan and arrange the installation location, networking mode, power supply, and cabling before installing the device. Confirm the following requirements before installation:

- The installation site provides sufficient space for heat dissipation.
- The installation site meets the temperature and humidity requirements of the device.

- The power supply and required current are available in the installation site.
- The Ethernet cables have been deployed in the installation site.

### 3.3 Mounting the Cabinet

#### Precautions

**When mounting the cabinet, you must pay attention to the following:**

- All expansion bolts for fastening the cabinet base to the ground should be installed and tightened in sequence from bottom to up (large flat washer, spring washer, and nut), and the installation holes on the base and the expansion bolts are properly aligned.
- The installed cabinet should not be moved.
- The installed cabinet should be vertical to the ground.
- When multiple cabinets are placed side by side in the machine room, they should be aligned with each other, leaving an error less than 5 mm (0.20 in.).
- The front/rear doors of the cabinet should be installed to allow you open and close them smoothly. The locks should work normally, and all keys should be complete.
- There should be no unnecessary and informal labels inside the cabinet and on service modules.
- Filler panels are installed in the empty slots.
- The screws in the cabinet should be fasten tightly and be of the same model.
- The device is securely installed, and the screws on the panel should be fastened tightly.
- All wiring outlets at the top and bottom of the cabinet should be installed with rodent-resistant nets with clearance of no more than 15 mm (0.59 in.) in diameter to prevent rodents and other small animals from entering the cabinet.
- ESD wrist straps should be provided in the cabinet.

#### Installation Steps

- (1) Plan the available space before installing the cabinet. Reserve enough space for the front and rear doors for device maintenance.
- (2) Install and fasten the cabinet in the designed position as planned.
- (3) Install the appropriate cable troughs and cables.
- (4) Install the tray and cable management brackets on the rack according to the number of devices installed into the cabinet.

### 3.4 Mounting the Switch

#### Precautions

Pay attention to the following:

- Connect the power cords of different colors to the corresponding cable terminals.
- Ensure the power cords are securely connected.
- Do not place heavy objects on the device.
- Maintain a minimum clearance of 100 mm (3.94 in.) around the device to ensure proper airflow. Do not stack

switches.

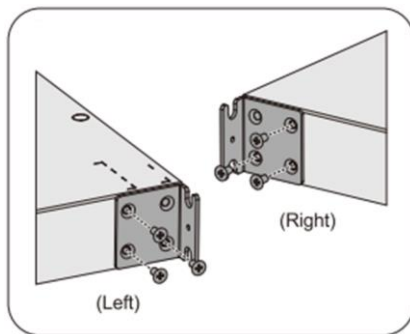
- Keep the device away from high-power radio launch pads, radar launch pads, and high-frequency large-current devices. Take electromagnetic shielding measures to minimize interference when necessary, for example, use shielded interface cables.
- Route interface cables only indoors to prevent signal ports from getting damaged by overvoltage or overcurrent caused by lightning strikes.

**Installing the Switch on a Rack**

The RG-CS86 series multi-GE switches meet the EIA standard, and can be installed in a 19-inch rack. During installation, place the device on the rack with the front panel facing forward. RG-CS86-48MG4VS2QXS-UPD, RG-CS86-24XMG4XS4VS-UPD switches are shipped with L brackets and shelf bracket rails. Shelf bracket rails are not provided for RG-CS86-24MG4VS-UP and RG-CS86-12XMG4VS-UP switches due to low depth of the switch.

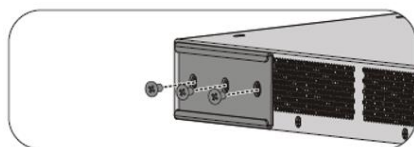
- Take out two L-shaped brackets and six M4x8 mm screws (delivered with the brackets). Secure one bracket to each side of the device using three M4x8 mm screws, as shown in Figure 3-1.

**Figure 3-1 Installing the Switch on a Rack (1)**



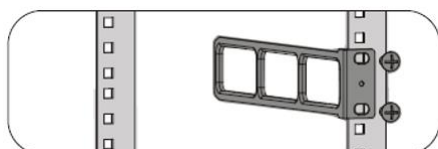
- Install the guide rails on both sides of the switch using screws, as shown in Figure 3-2.

**Figure 3-2 Installing the Switch on a Rack (2)**



- Install the rear mounting brackets on the rack, as shown in Figure 3-3.

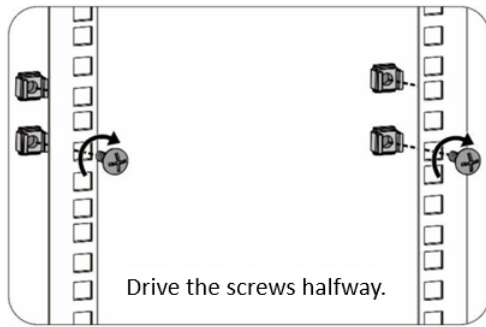
**Figure 3-3 Installing the Switch on a Rack (3)**



- Install two cage nuts on each side of the rack and drive the M6 screws halfway into the cage nuts, as shown in Figure 3-4.

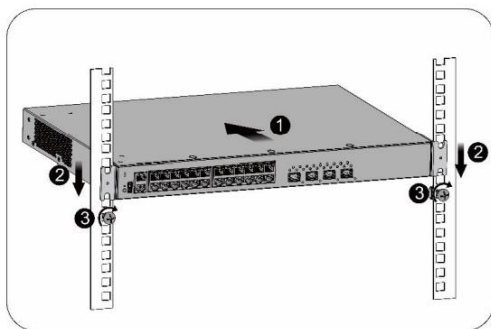


**Figure 3-4 Installing the Switch on a Rack (4)**



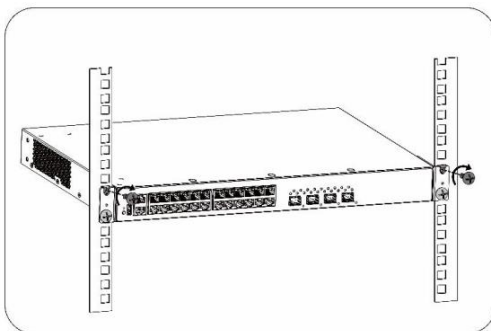
e. Secure the switch on the rack by tightening the screws, as shown in Figure 3-5.

**Figure 3-5 Installing the Switch on a Rack (5)**



f. Insert screws into the other two cage nuts and tighten them, as shown in Figure 3-6.

**Figure 3-6 Installing the Switch on a Rack (6)**



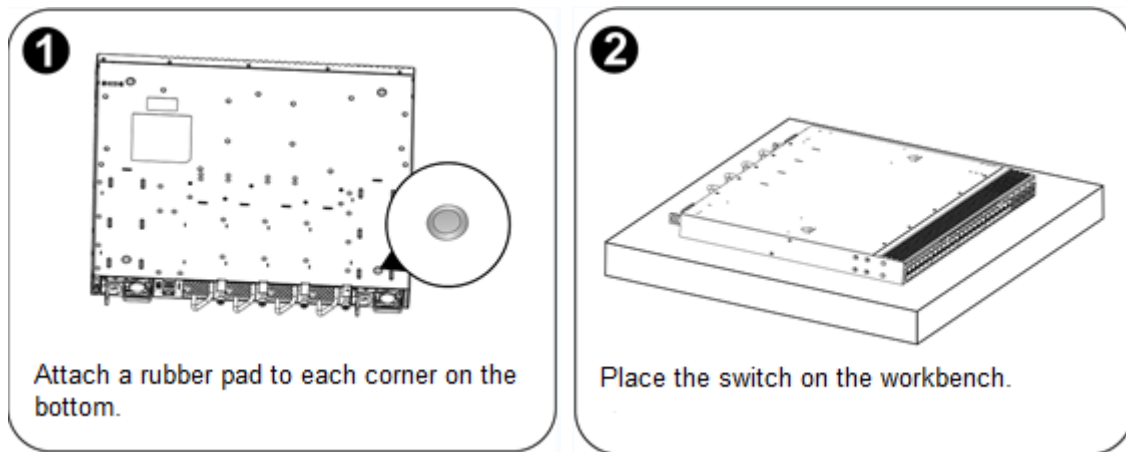
### Mounting on a Workbench

In some cases, if a standard 19-inch rack is not available, the switch can be mounted on a clean workbench.

The installation process is as follows:

- (1) Attach four rubber pads to the four corners at the bottom of the switch.
- (2) Place the switch on the workbench and ensure adequate airflow around the switch.

**Figure 3-7 Mounting on a Workbench**



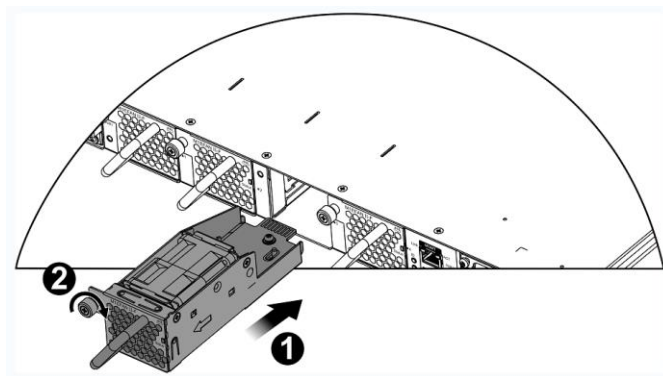
### 3.5 Installing and Removing a Fan Module

Wear an ESD wrist strap before performing the following operation.

#### Installing a Fan Module

- (1) Remove the fan module from its package.
- (2) Hold the handle at the end of the fan module. Insert the fan module to the chassis slowly along the guide rail until it is fully seated, and make sure that it is in good contact with the slot.
- (3) Tighten the captive screws with a screwdriver to fix the fan module in the switch chassis.

**Figure 3-8 Installing a Fan Module**



#### **⚠ Caution**

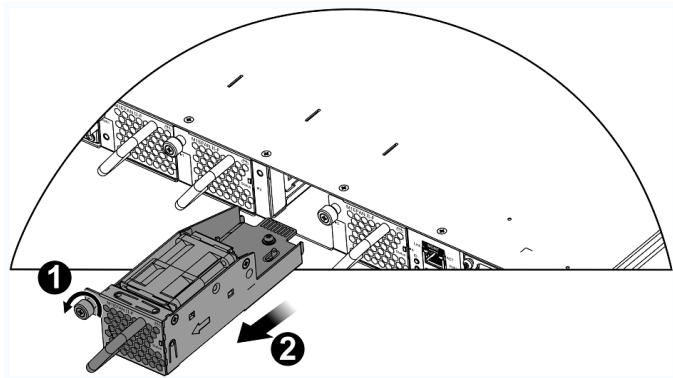
- Slide the fan module into the slot. Verify that the fan module is in the correct orientation.
- If you find it difficult to fully insert the fan module, pull the fan module out, and slide it into the slot again.
- If you find that the screws cannot be tightened, it is likely that the fan module is not fully inserted into the chassis. Check the fan modules carefully.
- Power modules and fan modules with different airflow direction cannot be used together.

#### Removing a Fan Module

- (1) Tighten the captive screws on the fan module with a screwdriver.
- (2) Hold the fan module latch and pull the fan module out gently.

- (3) Install the blank panel in the empty slot. Put the removed fan module back into its package.

**Figure 3-9 Removing a Fan Module**



**⚠ Caution**

- Make sure that the fan module is pulled out of the slot gently.
- Install the blank panel in the unoccupied slot to allow for adequate airflow.

## 3.6 Installing and Removing a Power Module

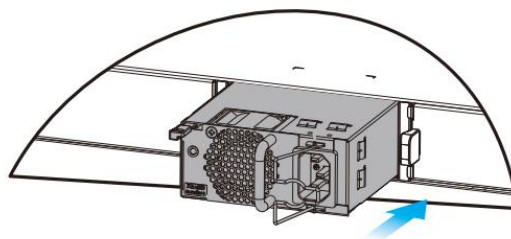
### 3.6.1 Installing and Removing a Power Module

Wear an ESD wrist strap before performing the following operation.

#### Installing a Power Module

- (1) Unpack the power module, and make sure the input specifications meet requirements.
- (2) Remove the blank panel in the empty slot. Keep the module nameplate face upward. Grasp the handle with one hand and place your other hand under the module to support its weight. Slide the module all the way into the slot along the guide rail until you feel the connector snap into place.

**Figure 3-10 Installing a Power Module**



**⚠ Caution**

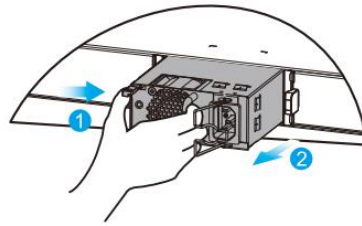
- Slide the power module into the slot gently. Verify that the power module is inserted in the correct orientation.
- If it is difficult or even impossible to insert the module, pull out the module, make sure the power module and guide rail are well aligned, and then insert the module again.

#### Removing a Power Module

- (1) Press the latch on the module and grasp the handle with one hand. Place your other hand under the module to support its weight. Pull the module fully out of the slot.

- (2) Install a blank panel in the power module slot and put the removed power module into its package.

**Figure 3-11 Removing a Power Module**



**⚠ Caution**

- Pull the power module out of the slot gently.
- Install a blank panel in the location where the power module is removed to ensure the normal ventilation and dissipation and avoid the dust in the chassis.

### 3.7 Grounding the Switch

A Ground cable is installed on the back of RG-CS86 series switch. First connect the Ground cable to the grounding terminal of the cabinet and then connect the grounding terminal to the grounding bar of the equipment room.

**Precautions**

- The sectional area of a grounding cable should be determined according to the possible maximum current. Grounding cables with good conductors should be used.
- Do not use bare wire.
- The resistance between the chassis and ground should be less than 1 ohm.

**⚠ Caution**

- To avoid personal injury and device damage, connect the switch to earth ground properly. The grounding resistance between the chassis and the ground should be less than 0.1 ohm.
- The O&M personnel should check whether the AC socket is reliably connected to the protective ground of the building. If not, the O&M personnel should use a protective earth conductor from the AC outlet protective earth terminal to the building protective earth.
- By means of a power cord connected to a socket-outlet with earthing connection.
- The power socket should be installed near the device and easily accessible.
- During the device installation, the ground connection must always be made first and disconnected last.
- The cross-sectional area of a protective ground cable should be at least 2.5 mm<sup>2</sup> (12 AWG).

### 3.8 Connecting the Console Port

**Steps**

Connect the RJ45 connector to the Console interface of the management engine module with shipped console cable, and connect the DB9 connector to the NM or control terminal.

**⚠ Caution**

By default, the baud rate is 9600, data bit 8, parity check none, stop bit 1, and flow control none.

## 3.9 Connecting the External Interface Cables

### Precautions

- Correctly distinguish single-mode and multi-mode fibers and ports.
- Avoid a small bend radius at the connector.

### Steps

- (1) Connect the RJ-45 connector of the delivered Ethernet cable to the management port of the switch and the other end to the management terminal.
- (2) Insert the SMF and MMF optical fibers into the corresponding ports according to the panel identification, and distinguish the transmitting and receiving ends of the optical fibers.
- (3) Insert the twisted pair cable with RJ45 connector into the corresponding ports according to the panel identification, and distinguish the crossover cable and the straight-through cable.

## 3.10 Bundling the Cables

### Precautions

- The power cords and other cables should be bound in a visually pleasing way.
- When you bind fibers, make sure that the fibers at the connectors have natural bends or bends of large radius.
- Do not bind fibers and twisted pair cables too tightly, as this may press hard the fibers and affect their useful life and transmission performance.

### Steps

- (1) Bind the drooping part of the optical cables and twisted pairs, and lead them to both sides of the chassis for convenience.
- (2) On both sides of the chassis, fasten the optical fibers and twisted pair cables to the cable management ring or cabling chute.
- (3) For the power cords, you should bind them closely along the bottom of the chassis, in a straight line wherever possible.

## 3.11 Verifying the Installation

### Verifying the Cabinet

- Verify that the external power supply matches with the distribution panel of the cabinet.
- Verify that the front/back cabinet doors can be closed after installing the device.
- Verify that the cabinet and all cables are securely fastened.
- Verify that the switch has been installed in the cabinet.
- Verify that a minimum clearance of 200 mm (7.87 in.) is maintained around the device for air circulation.

### Verifying the Cable Connections

- Make sure the UTP/STP cable matches with the interface type.
- Verify that cables are properly bundled.

- Verify that the grounding cables are connected properly and match the requirement.
- Verify that interface cables are routed indoors. If not, check whether the power supply and interfaces are protected from lightning strikes.

#### **Verifying the Power Supply**

Verify that the power cord is properly connected and compliant with safety requirements.

Connect the AC power with three pin plug power cord and the AC socket should be connected to the building protection ground.

---

 **Caution**

To avoid body injury and components damage, cut off power supply before checking the installation.

---

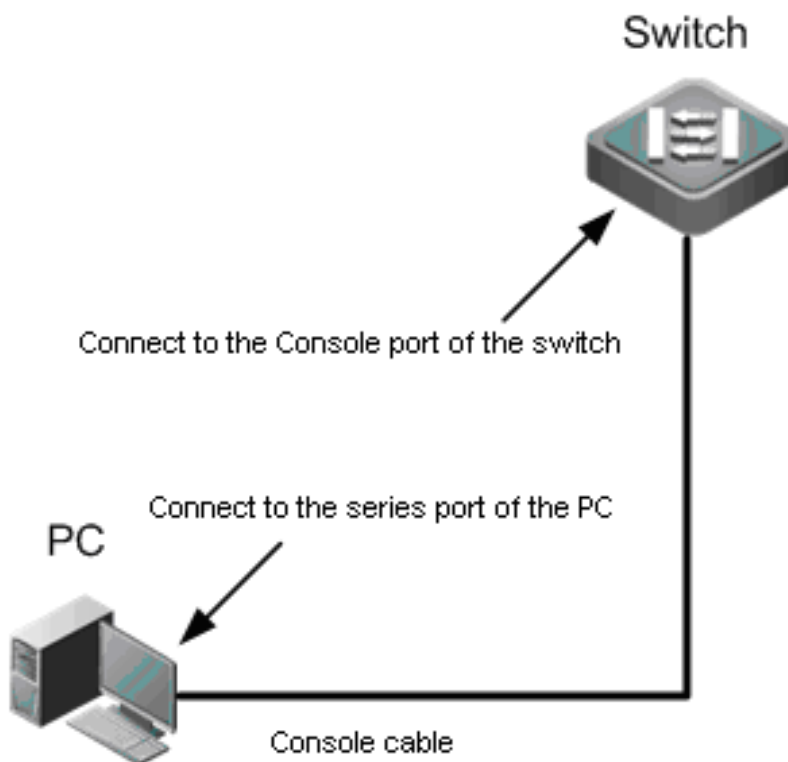
# 4 System Debugging

## 4.1 Setting Up the Configuration Environment

### Setting Up the Environment

Connect a PC to the console port of the switch by using an Ethernet cable, as shown in Figure 4-1.

Figure 4-1 Setting Up the Environment



### Connecting a Cable

- (1) Plug the crystal head of the network cable into the network port of the PC.
- (2) Connect the RJ45 end to the Console port on your AC.

### Setting Parameters

- Step 1: Start the PC and run the terminal simulation program on your PC, such as Terminal on Windows 3.1 or HyperTerminal on Windows 95/98/NT/2000/XP.
- Step 2: Set terminal parameters. Baud rate: 9600; Data bit: 8; Parity check: None; Stop bit: 1; Flow control: None. Follow the steps below to set the parameters:

Choose **Start > All Programs > Accessories > Communications > HyperTerminal**. The Location Information dialog box will appear.

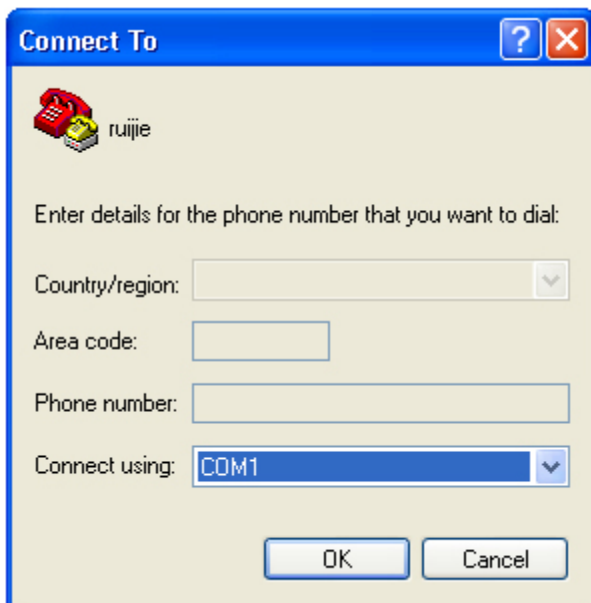
Click **Cancel**. The Connection Description dialog box will appear.

Figure 4-2



- (1) In the **Name** box, enter the new connection name and click **OK**. The **Connect to** dialog will appear. From the **Connect Using** drop-down list, select the **COM1** port to be used.

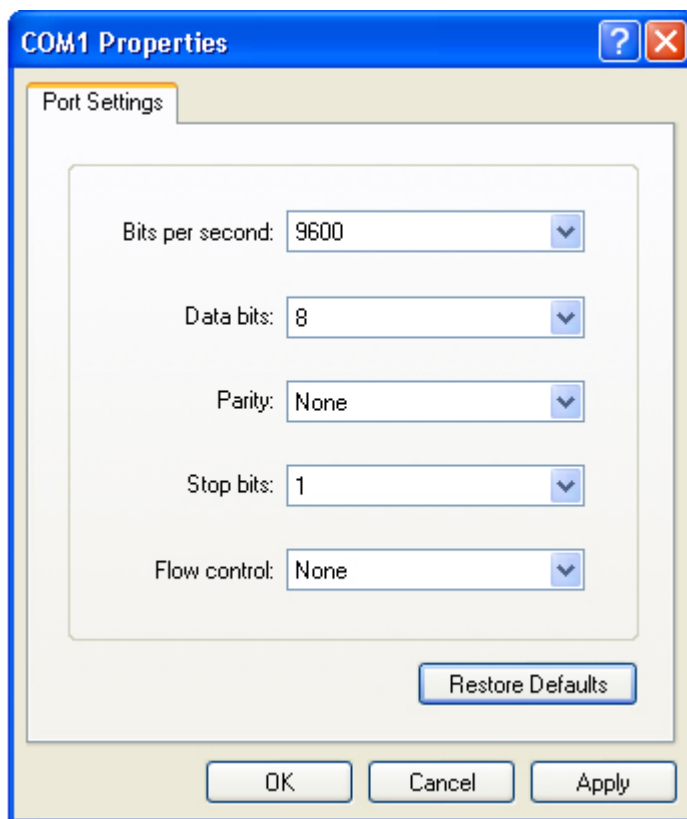
Figure 4-3



- (2) Click **OK**. The **COM1 Properties** dialog box will appear, as shown in Figure 4-4. Select the following settings: Bits per second: 9600; Data bits: 8; Parity: None; Stop bits: 1, and Flow control: None.



Figure 4-4



(3) Click **OK**. The **HyperTerminal** window will appear.

## 4.2 Powering on the Switch

### Checking Before Power-On

- Check that the device is properly grounded.
- Check that the power module is securely seated.
- Check that the power cord is properly connected.
- Check that the power supply voltage meets the requirement of the switch.
- Check that the network cable is properly connected, whether the client (may be PC) is started, and whether configuration parameters are configured.

### Checkingt after Power-on (Recommended)

After the device is powered on, you are recommended to perform the following checks to ensure the normal operation of follow-up configurations.

- Check that printed information appears on the terminal interface.
- Check that the device LED is normal.

# 5 Monitoring and Maintenance

## 5.1 Monitoring

### LEDs

When the device is running, you can monitor the module status by observing the LED.

- If the SYS indicator is red, it indicates that the system is faulty. Log in to the web-based management system to troubleshoot the fault.
- If the SYS indicator is yellow, it indicates that the system temperature reaches the warning value. This case may affect the system performance, but the system can continue working. Log in to the web-based management system to troubleshoot the fault.
- If the FAN LED is red, it indicates that a fan module is not functioning properly. Log in to the software management system to troubleshoot the fault.
- For example, if the Status LED on the device or expansion module keeps blinking or turns red, it indicates the switch is faulty. You are advised to identify the fault cause, and power off the switch when necessary.
- If the PWR1/PWR2 LED is red, it indicates that the power module is not functioning properly. You are advised to replace the power module.

### CLI Commands

You can run related commands on the CLI of the device to remotely monitor the device, including:

- System status
- Port configuration and status
- Fan and power supply status
- System temperature

---

### Note

For the monitoring commands, see the RG-CS86 Series Multi-GE Switches Configuration Guide.

---

## 5.2 Hardware Maintenance

### Maintenance of Expansion Modules

If the expansion module needs to be replaced in case of a failure, the operation instructions for installation and removal of the expansion module must be followed for replacing the expansion module.

### Cooling System Maintenance

- If the fan module fails, an alarm will be generated.
- Replace the failed fan module.
- Tighten the captive screws.




### Power module Maintenance

When a power module is faulty, unplug the power cord, replace the power module, plug the power cord in again.

### **Replacing Lithium Battery**

The device has a built-in lithium battery to maintain the real-time clock without external power.

To replace the lithium battery, contact technical support personnel.

- 
-  Risk of fire or explosion or defeat the safeguard of equipment if the battery is replaced by an incorrect type. Replace only with the same or equivalent type
  -  Leaving the battery in an extremely high temperature and/or low air pressure surrounding environment that can result in an explosion or the leakage of flammable liquid or gas
  -  Disposal of a battery into fire or a hot oven, or mechanically crushing or cutting of a battery, that can result in an explosion

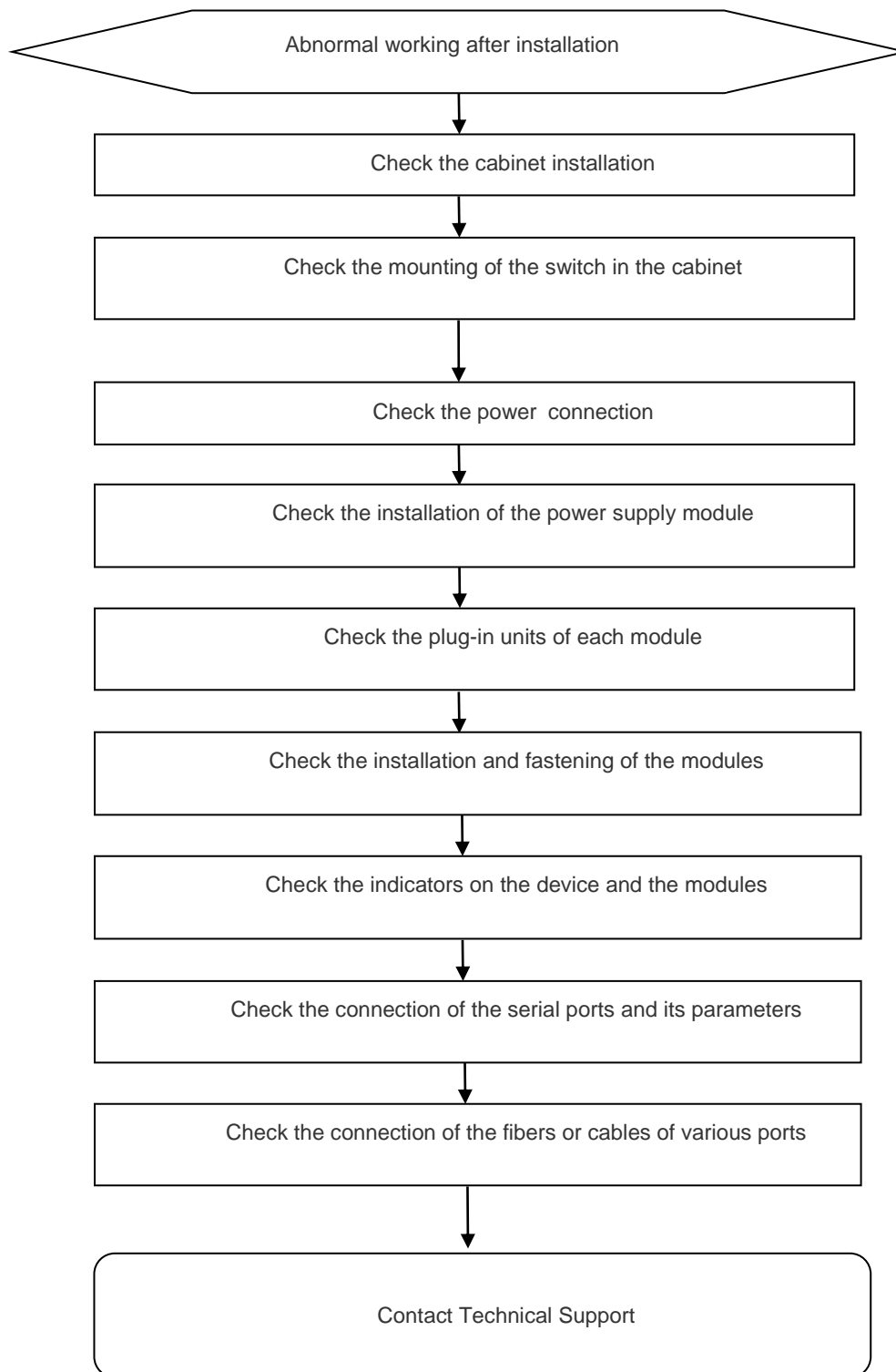
---

### **Replacing Fuses**

To replace fuses, contact technical support personnel. The technical support personnel will select fuses of the same specifications for replacement.

# 6 Troubleshooting

## 6.1 Troubleshooting Flowchart



## 6.2 Common Faults

### **Fault 1: The login password is forgotten.**

[Fault Description]

Failed to log into the system.

[Troubleshooting]

Contact Ruijie Networks Customer Service Department for technical support.

### **Fault 2: The AC power module does not work.**

[Fault Description]

All LEDs on the front panel are off. The fan status LED is off.

The power supply status LED is off. The fan does not rotate.

[Troubleshooting]

Unplug the power cord from the power module. Check the cable connection. Check whether the power cord is tightly connected to both the power socket and the power module. Check whether the power module is securely seated. If necessary, pull out the power module and check its connector.

### **Fault 3: The fan does not rotate.**

[Fault Description]

After the system is powered on, the fan does not rotate or the fan status LED is not on.

[Troubleshooting]

Check whether the fan module is securely seated. If yes, please replace the fan tray.

### **Fault 4: The serial port console has no output.**

[Fault Description]

After the system is started, the serial port console does not display any information.

[Troubleshooting]

Check the serial cable. Ensure that the connected serial port is consistent with what is configured on the HyperTerminal. Check whether the configuration of the serial port on the HyperTerminal is consistent with that in Configuration Guide. If there is still no output on the serial port, please contact Ruijie technical support.

### **Fault 5: The serial port console output is garbled.**

[Fault Description]

The serial port console output is garbled.

[Troubleshooting]

The fault is related to the serial port configuration. Check whether the baud rate configuration is consistent with that in Configuration Guide.

### **Fault 6: The new expansion module cannot be powered on.**

[Fault Description]

The system is running normally, but indicators on the panel of the new expansion module are off, and the port does not work normally.

[Troubleshooting]

Verify that the expansion module is inserted in place. If everything is normal, but the new module still cannot be powered on, contact Ruijie Networks Customer Service Department for technical support.

**Fault 7: The link of an optical port is down.**

[Fault Description]

After the SFP module is inserted into the SFP port and the fiber-optic cable is plugged in, the link cannot be set up on the SFP port.

[Troubleshooting]

Troubleshooting procedure:

- (1) Check whether the receiving end and transmitting end are reversed. The transmitting end of a fiber port must be connected to the corresponding receiver at the other end. You can confirm both ends by exchanging the connection order of two fiber-optic cables.
- (2) Check whether the wavelength of the SFP modules on the two sides are consistent. For example, an SFP module with a wavelength of 1310 nm cannot be connected to an SFP module of 1550 nm.
- (3) Check whether the distance between the two sides exceeds the maximum length marked on the SFP module.
- (4) Check whether the speeds of the two sides match and whether the optical fiber type meets requirements.

## Appendix A Connectors and Connection Media

### 10GBASE-T/5GBASE-T/2.5GBASE-T/1000BASE-T/100BASE-TX Port

The 10GBASE-T/5GBASE-T/2.5GBASE-T/1000BASE-T/100BASE-TX port supports five kinds of adaptive speeds and supports the automatic MDI/MDIX crossover function under at these five kinds of speeds.

#### 10GBASE-T

10GBASE-T is the Ethernet standard covering copper wiring, standardized in 2006 via the IEEE 802.3an standard. The 10GBASE-T port requires all four pairs of wires be connected for data transmission. The following figure shows the four pairs of wires for the 10GBASE-T port.

Cables	CAT7 STP	CAT6A STP	CAT6A UTP	CAT6 STP	CAT6 UTP
Description	Standard CAT7 shielded twist pairs	Standard CAT6A shielded twist pairs	Standard CAT6A unshielded twist pairs	Standard CAT6 shielded twist pairs	Standard CAT6 unshielded twist pairs
Type	Class F ISO/IEC 11801	Class Ea ISO/IEC 11801 Ed2.1/TIA-568-C.2		Class E ISO/IEC TR24750 TSB-155	
Max Transmission Distance	100 m	100 m		100 m	37 m to 55 m
Cabling System Bandwidth	600 MHz	500 MHz		250 MHz	
Description	Compliant with the minimum requirement of the 10GBASE-T standard			Compliant with the TSB-155 standard	

**Note**

- The CAT6 UTP cable exposed in severe condition may be influenced by external crosstalk. In this case, its maximum transmission cannot be longer than 37m.
- You are advised to use the CAT6A or CAT7 STP cable avoid as much external crosstalk as possible. Please pay attention to the device grounding when using the STP cable.
- The machine room has already been installed with the CAT6A CTP cable or CAT6 cable, compliant with the TSB-155 standard. The recommended cabling rules are as follows.
  - (1) Avoid mixed cabling with other cables. Otherwise, use metal plates in the cable trough to separate them.
  - (2) Separate the cables as far away from each other as possible and do not cross them. Most crosstalk occurs within a distance of 20 m (65.62 feet) away from the cable end. You are advised to not bundle the cables 5 m to 20 m (16.40 feet to 65.62 feet) away from the cable end.

If you need to bundle cables, you are advised to tie CAT6A UTP cables every 50 cm to 70 cm (19.69 in. to 27.56 in.), and the CAT6 UTP cables every 160 cm to 180 cm (62.99 in. to 70.87 in.).

---

- (3) Bundle cables as loosely as possible.
  - (4) Bind up to 12 cables into a bundle.
  - (5) Replace the CAT6 connector with the CAT6A connector.
- 

### 5GBASE-T

Compliant with the IEEE 802.3bz standard, 5GBASE-T requires Category 6 (CAT6) 100-ohm UTP or STP (STP is recommended) with a maximum distance of 100 meters.

---

#### Note

- CASE network cables are used for wiring in the machine room. 5G Base-T connections are not recommended.
  - 5GBASE-T is used for CAT6UTP transmission. CAT6UTP cable exposed in severe condition may be influenced by external crosstalk. In this case, its maximum transmission cannot be longer than 20m.
  - The Cat6 UTP network cables are used for wiring in the machine room. To meet the requirements of TIA TSB-5021, the recommended wiring rules are as follows:
    - (1) Avoid mixed cabling with other cables. Otherwise, use metal plates in the cable trough to separate them.
    - (2) The existing Cat6 UTP network cabling with a binding length below 20 meters can meet the minimum performance requirements of 5G BASE-T connections.
    - (3) 5 GBASE-T is recommended to be used at the device cable outlet. Separate the cables as far away from each other as possible and do not cross them. Most crosstalk occurs within a distance of 25 m (65.62 feet) away from the cable end. You are advised to not bundle the cables to 25 m (16.40 feet to 65.62 feet) away from the cable end.
    - (4) If you need to bundle cables, you are advised to loosely tie CAT6A UTP cables every 50 cm to 70 cm (19.69 in. to 27.56 in.). Bundle cables as loosely as possible.
    - (5) Tie up to 7 cables into a bundle.
    - (6) Replace the CAT6 connector with the CAT6A connector.
- 

### 2.5GBASE-T

Compliant with the IEEE 802.3bz standard, 2.5GBASE requires Category 5 or Category 5e 100-ohm UTP or STP (STP is recommended) with a maximum distance of 100 meters.

---

#### Note

- 2.5 GBASE-T is used for CAT5e UTP transmission. CAT5e UTP unshielded cable exposed in severe condition may be influenced by external crosstalk. In this case, its maximum transmission cannot be longer than 50m.
  - The CAT5e UTP network cables are used for wiring in the machine room. To meet the requirements of TIA TSB-5021, the recommended wiring rules are as follows:
    - (1) Avoid mixed cabling with other cables. Otherwise, use metal plates in the cable trough to separate them.
    - (2) The existing Cat5e UTP network cabling with a binding length below 50 meters can meet the minimum performance requirements of 2.5G BASE-T connections.
    - (3) Separate the cables as far away from each other as possible and do not cross them. Most crosstalk occurs within a distance of 25 m (65.62 feet) away from the cable end. You are advised to not bundle the cables 5 m to 25 m (16.40 feet to 65.62 feet) away from the cable end. 3.
    - (4) If you need to bundle cables, you are advised to loosely tie CAT5e UTP cables every 120 cm to 180 cm (47.24 in. to 70.87 in.). Bundle cables as loosely as possible.
    - (5) Tie up to 7 cables into a bundle.
-

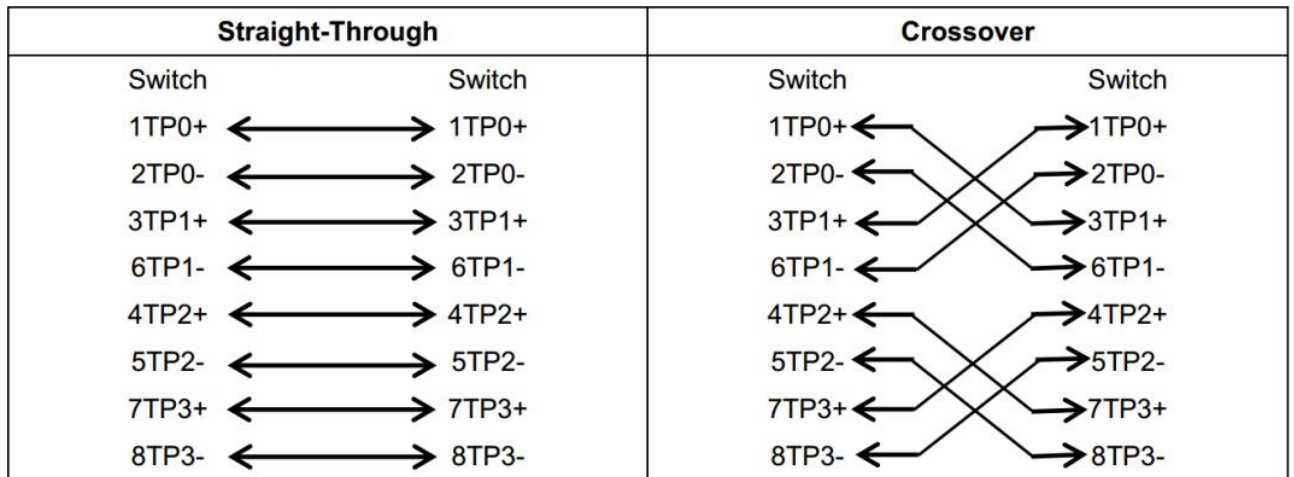


- (6) Replace the CAT5e connector with the CAT6 connector.

**1000BASE-T**

Compliant with IEEE 802.3ab, 1000BASE-T requires CAT5, 5E or higher 100-ohm twisted pairs with a maximum distance of 100 meters (328 feet). The 1000BASE-T port requires all four pairs of wires be connected for data transmission. Figure A-1 shows the connection of twisted pairs used by a 1000BASE-T port.

**Figure A-1 1000BASE-T Twisted Pair Connection**



**100BASE-TX**

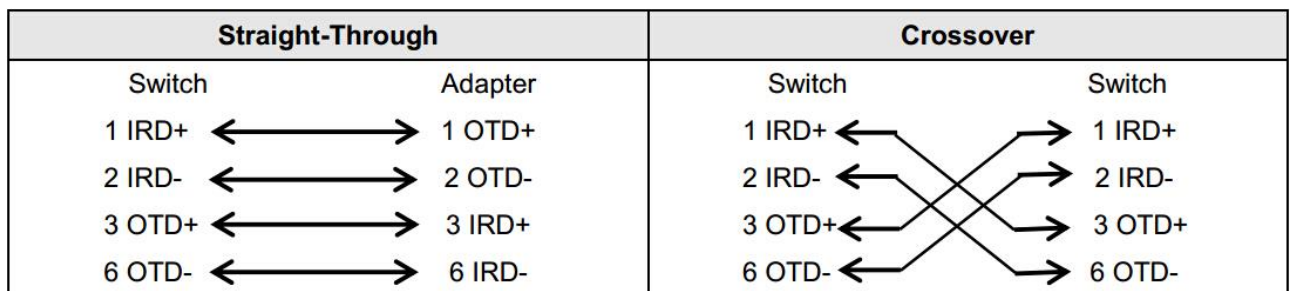
100BASE-TX also uses CAT5 100-ohm twisted pairs for connections with a maximum distance of 100 meters (328 feet). Figure A-2 shows 100BASE-TX pin assignments.

**Figure A-2 100BASE-TX Pin Assignments**

Pin↕	Socket↕	Plug↕
1↕	Input-Receive-Data+↕	Output-Transmit-Data+↕
2↕	Input-Receive-Data-↕	Output-Transmit-Data-↕
3↕	Output-Transmit-Data+↕	Input-Receive-Data+↕
6↕	Output-Transmit-Data-↕	Input-Receive-Data-↕
4, 5, 7, 8↕	Not-Used↕	Not-Used↕

Figure A-3 shows wiring of straight-through and crossover cables for 100BASE-TX.

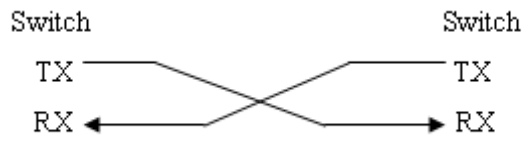
**Figure A-3 100BASE-TX Twisted Pair Connection**



**Optical Fiber Connection**

Please choose SMF or MMF optic cables according to the module types.

**Figure A-4 Fiber-Optic Cable Connection**



## Appendix B Mini-GBIC, 10GE, 25GE, 40GE and 100GE SFP Modules

We provide Gigabit SFP modules (Mini-GBIC modules), 10GE SFP+modules, 40GE QSFP+ modules, 100GE QSFP28 modules and AOC modules according to the SFP port types. You can select the module to suit your specific needs. This document provides models and technical specifications of some Gigabit SFP modules, 10G SFP+modules, 40G QSFP+ modules, 100G QSFP28 modules and AOC modules for reference. The following models and technical specifications of these modules are listed for your reference.

### Mini-GBIC (SFP) Optical Modules and Technical Specifications

GBIC/SFP	Wavelength (nm)	Fiber Type	DDM Supported (Yes/No)	Intensity of Transmitted Light (dBm)		Intensity of Received Light (dBm)	
				min	max	min	max
MINI-GBIC-SX-MM850	850	Multi-mode	No	-9.5	-3	-17	0
MINI-GBIC-LX-SM1310	1310	Single-mode	No	-9.5	-3	-20	-3
GE-eSFP-SX-MM850	850	Multi-mode	Yes	-9.5	-3	-17	0
GE-eSFP-LX-SM1310	1310	Single-mode	Yes	-9.5	-3	-20	-3
MINI-GBIC-LH40-SM1310	1310	Single-mode	Yes	-2	3	-22	-3
MINI-GBIC-ZX50-SM1550	1550	Single-mode	Yes	-5	0	-22	-3
MINI-GBIC-ZX80-SM1550	1550	Single-mode	Yes	0	4.7	-22	-3
MINI-GBIC-ZX100-SM1550	1550	Single-mode	Yes	0	5	-30	-9
GE-SFP-LX20-SM1310-BIDI	1310TX/1550RX	Single-mode	Yes	-9	-3	-20	-3
GE-SFP-LX20-SM1550-BIDI	1550TX/1310RX	Single-mode	Yes	-9	-3	-20	-3
GE-SFP-LH40-SM1310-BIDI	1310TX/1550RX	Single-mode	Yes	-5	0	-24	-1

GE-SFP-LH40-SM1550-BIDI	1550TX/1310RX	Single-mode	Yes	-5	0	-24	-1
SFP-S4-R1000P1 V1	1310	Single-mode	No	-9.5	-3	-20	-3

**⚠ Caution**

- According to the received light intensity index, for the following modules, when using short-distance single-mode fiber, an online optical attenuator should be inserted in the link to avoid damage to the optical module. These modules include GE-SFP-LH40-SM1310-BIDI, GE-SFP-LH40-SM1550-BIDI, MINI-GBIC-LH40-SM1310, MINI-GBIC-ZX50-SM1550, MINI-GBIC-ZX80-SM1550, MINI-GBIC-ZX100-SM1550, SDH155-SFP-LH40-SM1310, and SDH155-SFP-LH80-SM1550.
- An optical transceiver is a laser transmitter. Do not look into the light source to prevent it from burning your eyes.
- To keep the optical transceiver clean, make sure that the unused ports remain capped.

**Cabling Specifications (Continued)**

GBIC/SFP	Wavelength (nm)	Fiber Type	Core Specifications (μm)	Max. Cabling Distance
MINI-GBIC-SX-MM850	850	Multi-mode	62.5/125	275 m
			50/125	550 m
MINI-GBIC-LX-SM1310	1310	Single-mode	9/125	10 km
GE-eSFP-SX-MM850	850	Multi-mode	62.5/125	275 m
			50/125	550 m
GE-eSFP-LX-SM1310	1310	Single-mode	9/125	10 km
MINI-GBIC-LH40-SM1310	1310	Single-mode	9/125	40 km
MINI-GBIC-ZX50-SM1550	1550	Single-mode	9/125	50 km
MINI-GBIC-ZX80-SM1550				80 km
MINI-GBIC-ZX100-SM1550				100 km
GE-SFP-LX20-SM1310-BIDI	LC	Single-mode	9/125	20 km
GE-SFP-LX20-SM1550-BIDI	LC	Single-mode	9/125	20 km
GE-SFP-LH40-SM1310-BIDI	LC	Single-mode	9/125	40 km

GE-SFP-LH40-SM1550-BIDI	LC	Single-mode	9/125	40 km
SFP-S4-R1000P1 V1	1310	Single-mode	9/125	10 km

**Pairing of SFP BIDI Optical Modules**

Rate/Distance	Pairing Model
GE/20 km	GE-SFP-LX20-SM1310-BIDI GE-SFP-LX20-SM1550-BIDI
GE/40 km	GE-SFP-LH40-SM1310-BIDI GE-SFP-LH40-SM1550-BIDI

**⚠ Caution**

BIDI optical modules must be used in pairs. If GE-SFP-LX20-SM1310-BIDI is used at one end, then GE-SFP-LX20-SM1550-BIDI must be used at the other end.

**Mini-GBIC (GT) Optical Modules and Technical Specifications**

Current models of SFP electric port modules:

Standard	1000Base-T SFP Module
1000Base-T	Mini-GBIC-GT

**1000Base-T Port Cabling Specifications (Continued)**

1000baseT	Copper Cable Type	Max. Cabling Distance	DDM Supported (Yes/No)
Mini-GBIC-GT	Standard Cat-5 and above unshielded or shielded twist pairs	100 m	No

**i Note**

10G Ethernet ports of the device does not support the Mini-GBIC-GT photoelectric modules.

**10G SFP+ Optical Modules and Technical Specifications**

Current models of 10G SFP+ optical modules:

Model	Wavelength (nm)	Fiber Type	Core Size (um)	Modular Bandwidth (MHz·km)	Max. Cabling Distance	Intensity of Transmitted Light (dBm)		Intensity of Received Light (dBm)	
						min	max	min	max
XG-SFP-SR-MM8	850	Multi-mode	62.5	200	33 m	-5	-1	-7.5	0.5
				160	26 m				

50		fiber (LC conne ctor)	50	2000	300 m				
				500	82 m				
				400	66 m				
XG-SFP- LR-SM1 310	1310	Single -mode fiber (LC conne ctor)	9	N/A	10 km	-8. 2	0.5	-10 .3	0.5
XG-SFP- ER-SM1 550	1550	Single -mode fiber (LC conne ctor)	9	N/A	40 km	-4. 7	4	-11 .3	-1
XG-SFP- ZR-SM1 550	1550	Single -mode fiber (LC conne ctor)	9	N/A	80 km	0	4	-2 4	-7
SFP-M3- R1000P1	850	Multi- mode fiber (LC conne ctor)	62.5	200	33 m	-5	-1	-7. 5	0.5
				160	26 m				
			50	2000	300 m				
				500	82 m				
				400	66 m				
SFP-S1- R1000P1	1310	Single -mode fiber (LC conne ctor)	9	N/A	10 km	-8. 2	0.5	-10 .3	0.5
SFP-S4- R1000P1 V2	1310	Single -mode fiber	9	N/A	10 km	-8. 2	0.5	-10 .3	0.5

		(LC connector)							
--	--	----------------	--	--	--	--	--	--	--

Current models of 10G SFP+ copper cable modules:

Model	Module Type	Connector Type	Copper Cable Length (m)	Conductor Diameter (AWG)	Rate (Gbps)	DDM Supported (Yes/No)
XG-SFP-CU1M	Passive	SFP+	1	28	10.3125	No
XG-SFP-CU3M	Passive	SFP+	3	28	10.3125	No
XG-SFP-CU5M	Passive	SFP+	5	26	10.3125	No

**Models of 25G SFP28 Optical Modules and Technical Specifications**

Current models of 25G SFP28 optical modules:

Model	Wavelength (nm)	Fiber Type	Core Size (um)	Modular Bandwidth (MHz·km)	Max. Cabling Distance	Intensity of Transmitted Light (dBm)		Receiving Sensitivity (dbm)	
						min	max	min	max
VG-SFP-SR-MM850	850	Multi-mode	50	4700	100m	-8.4	2.4	-10.3	2.4
VG-SFP-LR-SM1310	1310	Single-mode	9	N/A	10KM	-4.5	3	-11.4	2

**Note**

25G SFP28 ports of the device, when operating at 25G rate, support optical modules, but do not support Direct Attach Copper (DAC) cables.

**Models of 40G QSFP+ Optical Modules and Technical Specifications**

Current models of 40G QSFP+ optical modules:

Model	Wavelength (nm)	Fiber Type	Core Size (um)	Modular Bandwidth (MHz·k)	Max. Cabling Distance	DDM Supported (Yes/No)	Intensity of Transmitted	Intensity of Received Light
-------	-----------------	------------	----------------	---------------------------	-----------------------	------------------------	--------------------------	-----------------------------

				(m)	nce	)	Light (dBm)	(dBm)
40G-Q SFP-SR-MM850	850	Multi-mode (MPO connector)	50	2000	100 m (OM3)	Yes	-7.6 to 2.4 (Per lane)	-9.5 to 2.4 (Per lane)
			50	4700	150 m (OM4)			
40G-Q SFP-L SR-MM850	850	Multi-mode (MPO connector)	50	2000	300 m (OM3)	Yes	-7.6 to 2.3 (Per lane)	-9.9 to 2.4 (Per lane)
			50	4700	400 m (OM4)			
40G-Q SFP-L R4-SM1310	1310	LC	9	N/A	10 km	Yes	-7.0 to 2.3 (Per lane)	-13.7 to 2.3 (Per lane)

Current models of 40G QSFP+ copper cable modules:

Model	Module Type	Connector Type	Copper Cable Length (m)	Conductor Diameter (AWG)	Rate (Gbps)	DDM Supported (Yes/No)
40G-QSFP-STACK1M	Passive	QSFP+	1	28	4lanes*10.3125 (Per lane)	No
40G-QSFP-STACK3M	Passive	QSFP+	3	28	4lanes*10.3125 (Per lane)	No

**Models of 100G QSFP28 Optical Modules and Technical Specifications**

Current models of 100G QSFP28 optical modules:

Model	Wavele	Fiber Type	Cor	Modular	Max.	DDM	Intensity	Intensity
-------	--------	------------	-----	---------	------	-----	-----------	-----------



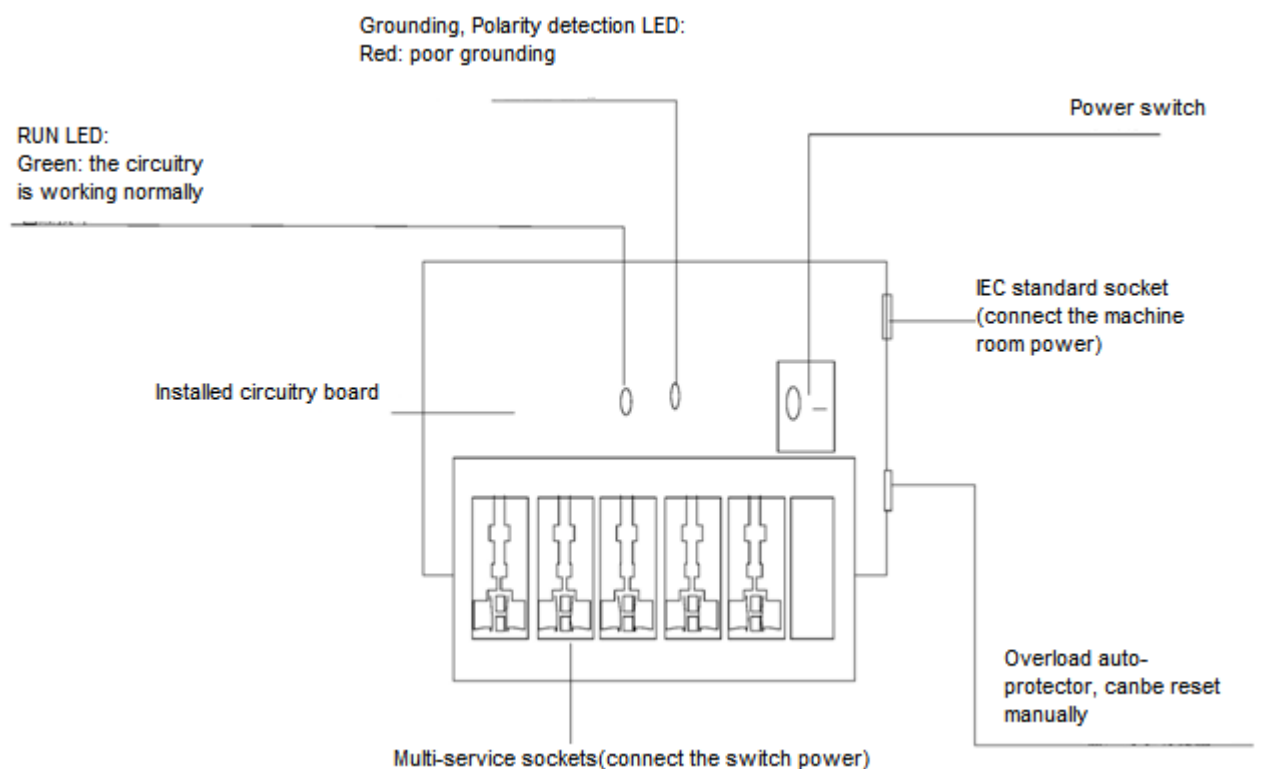
	Length (nm)		Fiber Core Size ( $\mu\text{m}$ )	Bandwidth (MHz·km)	Cabling Distance	Supported (Yes/No)	Transmitted Light (dBm)	Received Light (dBm)
100GB ASE-S R4 QSFP28 optical modules	850	Multi-mode (MPO connector)	50	2000	70 m (OM3)	Yes	-8.4 to 2.4 (Per lane)	-10.3 to 2.4 (Per lane)
			50	4700	100 m (OM4)			
100GB ASE-L R4 QSFP28 optical modules	1301	LC	9	N/A	10 km	Yes	-4.3 to 4.5 (Per lane)	-10.6 to 4.5 (Per lane)

## Appendix C Lightning Protection

### Installing an AC Power Arrester (Lightning Resistance Socket)

When an AC power cord is introduced from outdoors and directly connected to the power port of the switch, the AC power port must be connected to an external lightning protection power strip to protect the switch against lightning strokes. The lightning resistance socket can be fixed on the rack, workbench, or wall in the machine room by using cable ties and screws. AC power enters the lightning protection power strip and then enters the switch.

Figure C-1 Power Arrester



#### **Note**

The power arrester is not delivered with the switch. Please purchase it based on actual requirements.

#### Precautions:

- Make sure that the PE terminal of the power arrester is well grounded.
- After the AC power plug of the switch is connected to the socket of the power arrester (lightning resistance socket), the lightning protection function is implemented only if the RUN indicator is green and the ALARM indicator is OFF.
- If the ALARM indicator on the power arrester is red, check whether it is caused by poor grounding connection or by the reversed connection of the Null and Live lines. The detection method is as follows: Use a multimeter to measure the polarity of the power socket for the arrester when the indicator is red. If the N line is on the left and the L line is on the right (facing the socket), the arrester's PE terminal is not grounded.

If not, the polarity of the arrester power cord should be reversed. In this case, you should open the power arrester and rectify the polarity of the connection. If the indicator is still red, the arrester's PE terminal is not grounded.

**Installing the Ethernet Port Arrester**

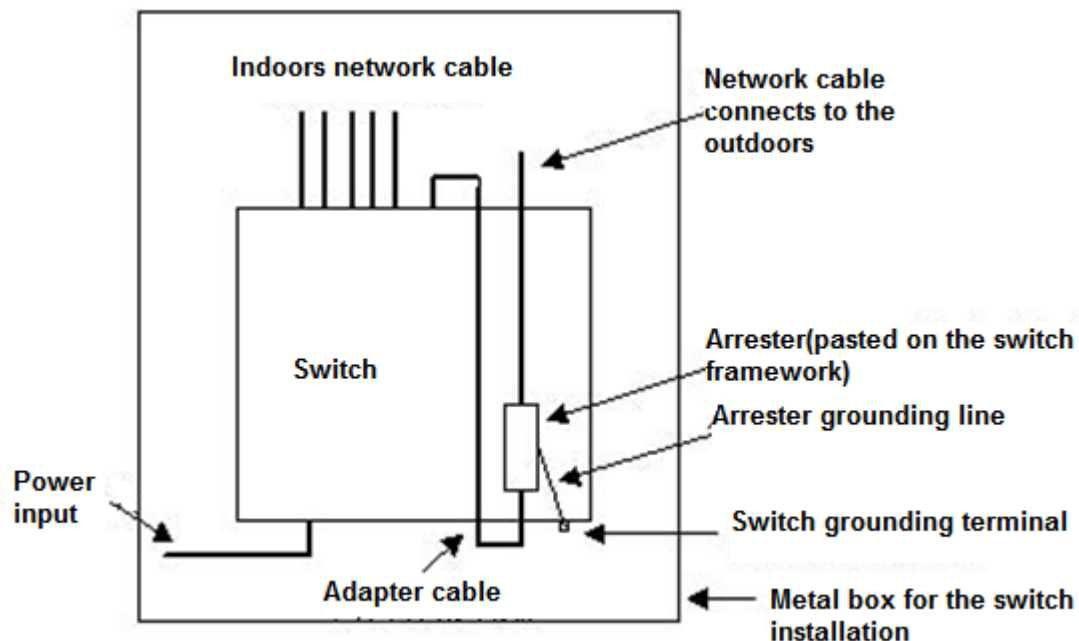
Connect an Ethernet port arrester to the switch to prevent the damage by lightning before connecting an outdoor network cable to the switch.

Tools: Phillips screwdrivers or flat-head screwdriver, multimeter, and diagonal pliers

Installation steps:

- (1) Tear one side of the protective paper for the double-sided adhesive tape and paste the tape to the enclosure of the Ethernet port arrester. Tear the other side of the protective paper for the double-sided adhesive tape and paste the Ethernet port arrester to the switch enclosure. The paste position for the Ethernet port arrester should be as close to the grounding terminal of the switch as possible.
- (2) According to the distance between the switch grounding terminal and the Ethernet port arrester, cut the grounding cable for the Ethernet port arrester and firmly crimp the grounding cable to the grounding terminal of the switch.
- (3) Use a multimeter to check whether the grounding cable for the arrester is in good contact with the grounding terminal and the enclosure of the switch.
- (4) Connect the arrester by using an adapter cable (note that the external network cable is connected to the IN end, while the adapter cable connected to the switch is connected to the OUT end) and check whether the service module LED is normal.
- (5) Use a nylon cable tie to bind the power cords.

**Figure C-2 Installation of the Ethernet Port Arrester**



**i Note**

- The Ethernet port arrester is only for the 10/100 Mbps copper ports with an RJ-45 connector.
- The Ethernet port arrester is not delivered with the switch. Please purchase it based on actual requirements.  
The Ethernet port arrester user manual contains technical parameters and maintenance and installation instructions for the Ethernet port arrester. Carefully read this manual before installation.

---

Pay attention to the following situations during the actual installation to avoid influencing the performance of the Ethernet port arrester:

- Reversed installation direction of the arrester. Connect the external network cable to the "IN" end and connect the Ethernet port of the switch to the "OUT" end.
- Poor grounding of the arrester. The grounding cable of the arrester should be as short as possible to ensure that it is in good contact with the grounding terminal of the switch. Use a multimeter to confirm the contact condition after grounding.
- Incomplete arrester installation. If there is more than one port connected to the peer device on the switch, arresters need to be installed on all connection ports for the purpose of lightning protection.

## Appendix D Cabling Recommendations

When the switch is installed in a standard 19-inch rack, secure the cables around the cable management brackets. Adopt top cabling or bottom cabling according to the actual situation in the machine room. All adapted connectors should be placed at the bottom of the rack in an orderly manner instead of outside the rack that is easy to touch. Power cords are routed beside the rack. Top cabling or bottom cabling is adopted according to the actual situation in the machine room, such as the positions of the DC power distribution box, AC socket, or lightning protection box.

### Requirement for the Minimum Cable Bend Radius

- The bend radius of a power cable, communication cable, or flat cable should be over five times greater than their respective diameters. The bend radius of these cables that is often bent or plugged or unplugged should be over seven times greater than their respective diameters.
- The bend radius of a fixed common coaxial cable should be over seven times greater than its diameter. The bend radius of the common coaxial cable that is often bent or plugged should be over 10 times greater than its diameter.
- The minimum bend radius of a high-speed cable, such as an SFP+ cable, should be 5 times the overall diameter of the cable. If the cable is constantly bent, plugged or unplugged, the bend radius should be 10 times the overall diameter.

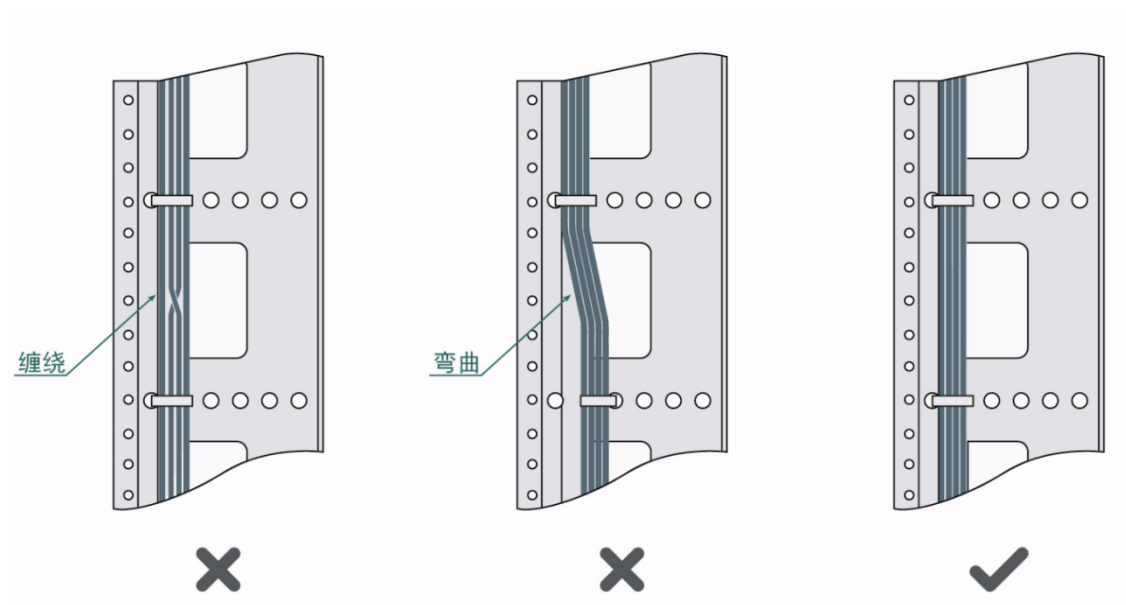
### Requirement for the Minimum Bend Radius of an Optical Fiber

- The diameter of a fiber tray to hold fibers should be over 25 times greater than the diameter of the fiber..
- When an optical fiber is moved, the bend radius of the fiber should be over 20 times greater than the diameter of the fiber.
- During cabling of an optical fiber, the bend radius of the fiber should be over 10 times greater than the diameter of the fiber.

### Precautions for Bundling up Cables

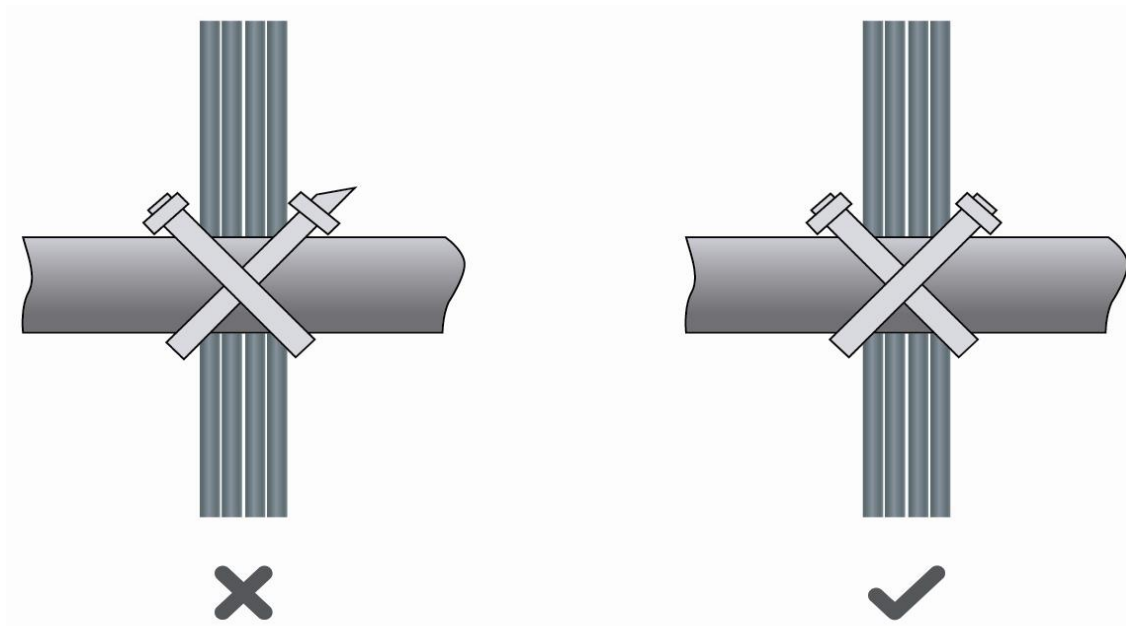
- Before cables are bundled, mark labels and stick the labels to cables wherever appropriate.
- Cables should be neatly and properly bundled in the rack without twisting or bending, as shown in Figure D-1.

**Figure D-1 Binding Cables (1)**



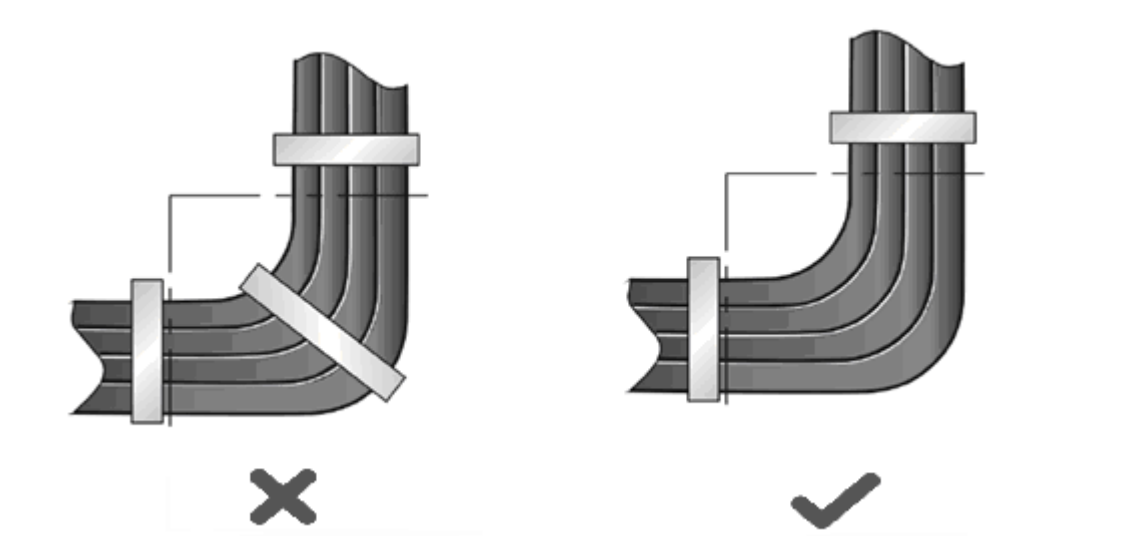
- Cables of different types (such as power cords, signal cables, and ground cables) should be separated in cabling and bundling. Mixed bundling is disallowed. When they are close to each other, you are advised to adopt crossover cabling. In the case of parallel cabling, maintain a minimum distance of 30 mm (1.18 in.) between power cords and signal cables.
- The cable management brackets and cabling troughs inside and outside the rack should be smooth without sharp corners.
- The metal hole traversed by cables should have a smooth and fully rounding surface or an insulated lining.
- Use cable ties to bundle up cables properly. Please do not connect two or more cable ties to bundle up cables.
- After bundling up cables with cable ties, cut off the remaining part. The cut should be smooth and trim without sharp corners, as shown in Figure D-2.

Figure D-2 Binding Cables (2)



- When cables need to be bent, please bundle them up but do not tie cable ties within the bend. Otherwise, stress may be generated on the cables and causes the wires inside to break, as shown in Figure D-3.

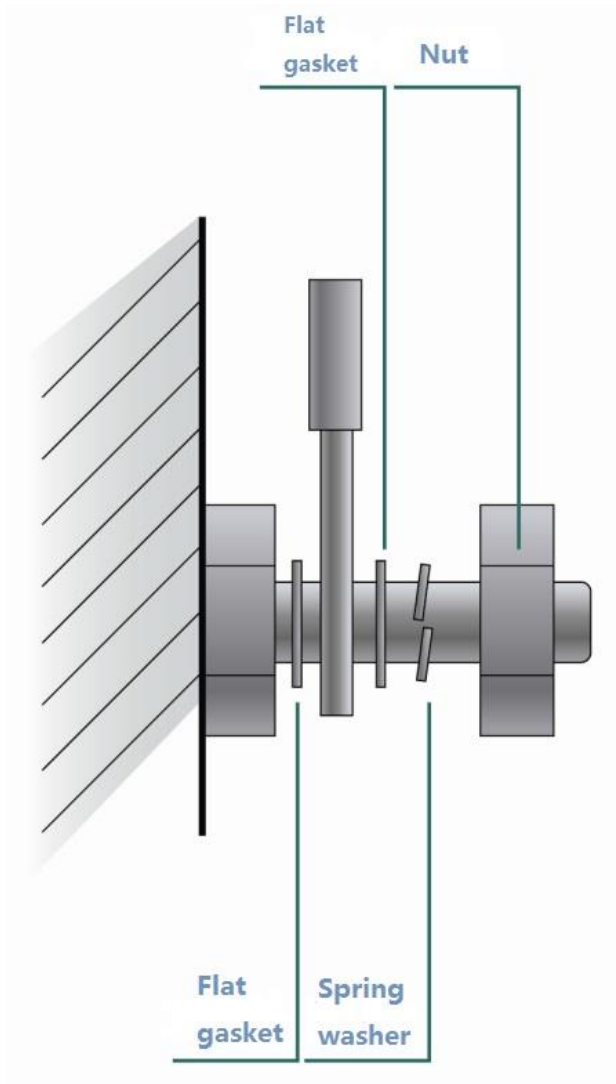
Figure D-3 Binding Cables (3)



- Cables not to be assembled or remaining parts of cables should be folded and placed in a proper position of the rack or cable trough. The proper position indicates a position that will not affect device running or cause device damage or cable damage during debugging.
- Do not bind power cords to the guide rails of moving parts.
- The power cords connecting moving parts such as door grounding cables should be reserved with some excess after being assembled. This can avoid tension or stress on power cords. After the moving part is installed, the remaining cable part should not touch heat sources, sharp corners, or sharp edges. If heat sources cannot be avoided, high-temperature cables should be used.
- When screw threads are used to fasten a cable terminal, the bolt or screw must be tightly fastened, and

measures should be taken to retain the terminal, as shown in Figure D-4.

**Figure D-4 Cable Fastening**



- Hard power cords should be fastened in the terminal connection area to prevent stress on terminal connection and cable.
- Do not use self-tapping screws to fasten terminals.
- Power cords of the same type and in the same cabling direction should be bundled up into cable bunches, with cables in cable bunches clean and straight.
- Bundle up cables by using cable ties.

Cable Bunch Diameter (mm)	Binding Spacing (mm)
10	80 to 150
10 to 30	150 to 200
30	200 to 300

- No knot is allowed in cabling or binding.
- For wiring terminal blocks (such as circuit breakers) with cord end terminals, the metal part of the cord end



terminal should not be exposed outside the terminal block when assembled.

## Appendix E Site Selection

- The machine room should be at least 5 km (3.11 miles) away from heavy pollution sources, such as the smelter works, coal mine, and thermal power plant. The machine room should be at least 3.7 km (2.30 miles) away from medium pollution sources, such as the chemical factory, rubber factory, and electroplating factory. The machine room should be at least 2 km (1.24 miles) away from light pollution sources, such as the food factory and leather plant. If the pollution source is unavoidable, the machine room should be located on the windward side of the pollution source perennially with advanced protection.
- The machine room should be at least 3.7 km (2.30 miles) away from the sea or salt lake. Otherwise, the machine room must be sealed, with air conditioner installed for temperature control. Saline soil cannot be used for construction. Otherwise, you should select devices with advanced protection against severe environment.
- Do not build the machine room in the proximity of livestock farms. Otherwise, the machine room should be located on the windward side of the pollution source perennially. The previous livestock house or fertilizer warehouse cannot be used as the machine room.
- The machine room should be firm enough to withstand severe weather conditions such as windstorm and heavy rain as well as away from dust. If the dust is unavoidable, keep the door and window away from the pollution source.
- The machine room should be away from the residential area. Otherwise, the machine room should meet the construction standard in terms of noise.
- Make sure the air vent of the machine room is away from the sewage pipe, septic tank, and sewage treatment tank. Keep the machine room under positive pressure to prevent corrosive gas from entering the machine room to corrode components and circuit boards.
- Keep the machine room away from industrial boiler and heating boiler.
- The machine room should be on the second floor. Otherwise, the machine room floor should be 600 mm (23.62 in.) higher than the highest flood level ever recorded.
- Make sure there are no cracks or holes in the wall and floor. If there are cable entries in the wall or window, take proper sealing measures. Ensure that the wall is flat, wear-resistant, and dust-free, which should be up to the standard for flame retarding, soundproofing, heat absorption, dust reduction, and electromagnetic shielding.
- Keep the door and the window closed to make the machine room sealed.
- The steel door is recommended for soundproofing.
- Sulfur-containing materials are forbidden.
- Keep the air conditioner from blowing wind straight toward the device or blowing water drops from the window or air vent toward the device.

## Appendix F Ruijie Intelligent Tech Assistant



扫码获取帮助  
Scan the QR code to get help

(Ruijie Intelligent Tech Assistant QR Code)

- Ruijie Networks Intelligent Service: <http://yixiu.ruijie.com.cn:8888/robot/interface/index.html>

Ruijie Intelligent Tech Assistant covers the most complete knowledge content and the highest search hit rate.

- Ruijie Networks website: <http://www.ruijie.com.cn/>

You can obtain the latest product technical data, product troubleshooting analysis, application solutions, software upgrade information, and so on on the official website.

- Ruijie Networks Customer Service: 4008-111-000

A 7x24 technical service hotline.